

# Secret High Power Free Energy Circuit (AEC)

Under: Free Energy Circuits

This is a Tesla/joule thief hybrid circuit that its inventor claim to produce 90 times the input power! The circuit can be self looped and can provide 1050W of power. from the 1050W only the 11.6W will loop back to supply the joule thief. If you remove the bridge rectifier and the C capacitor you can use the circuit with high frequency AC output. The circuit uses the 2n3055 and a regular bifilar coil `BC` (45+45 turns, 0.5mm wire) to pulse the ferrite core which consist of two large U shape ferrites. The Coils CC1, CC2 and CC3 are not ordinary coils, Are Capacitor/coils combination.

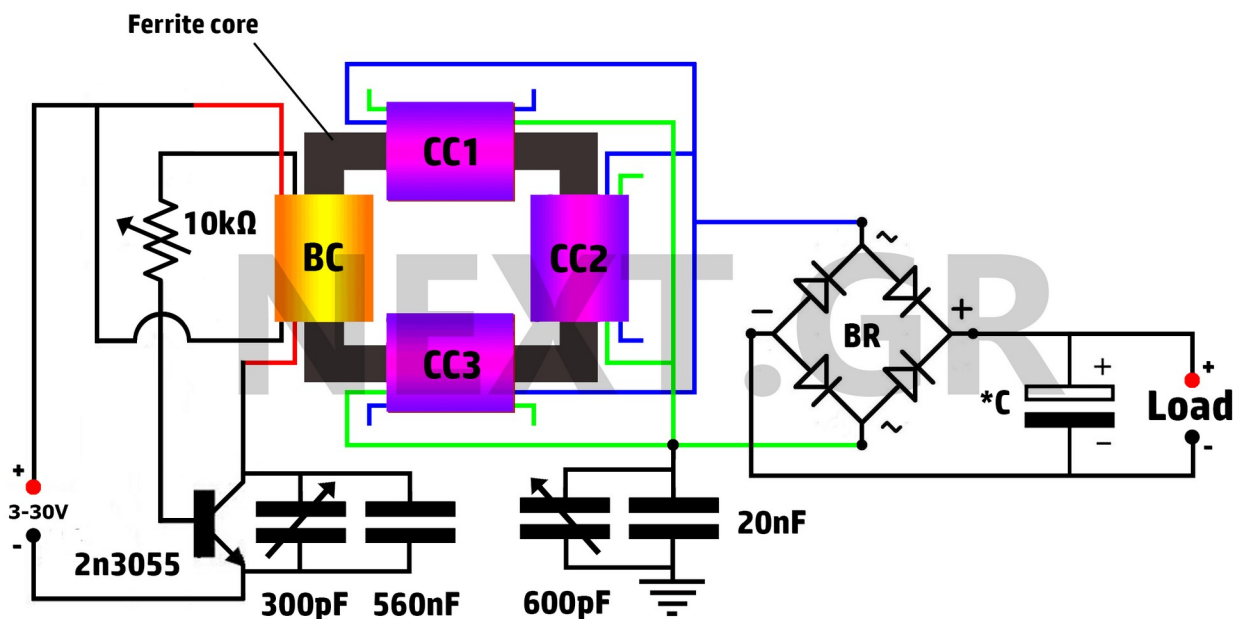

Click [here](#) to download the full size of the above Circuit.

Those coils are no more than two aluminum foils taken from the guts of a large electrolytic capacitor and wound on the ferrite core with a dielectric insulator between them, Plastic film in that case. Each Coil/capacitor has 60 turns of foil pairs. Inductance should be around 0.53mH and the forming capacitance 48 $\mu$ F for each finished coil.

So each coil/capacitor has four terminal ends and not two as a regular capacitor has. Two at start and two at the end. The circuit use three of these coils for the output. Try to make them as identical as they can be. Capacitors may need to be changed according to the forming capacitance and inductance of your coils. The two variable capacitors and the variable resistor are needed to tune the circuit to resonate.

The earth connection must be good and must be completely separate from the house mains earth. Start with low power, put 3 volts at the joule thief and gradually increase the voltage with the load connected.

Tune first the variable resistor for best output, and then tune the variable capacitors to match the frequencies. Be very careful while you playing with this unit. You should be expert in high voltage if you decide to experiment with this circuit. If tuned properly, its output can shock you very badly or even kill you.

Free energy battery charger

Under: Free Energy Circuits

As the circuit operates, the three sets of diodes with their isolation capacitors, build up an increasing voltage on capacitor ?C1?. The voltage at point ?B? will also increase and be about twelve volts less than the voltage on capacitor ?C1?. Eventually, that voltage will rise high enough to cause a discharge through the tiny neon tube and that current pulse flows through the Gate connection ?G? of the thyristor, switching it on. Once switched on, the thyristor stays on until capacitor ?C1? has been discharged, after which, the thyristor switches off and the process starts all over again. The amount of power in these pulses is considerable and the thyristor gets quite warm when the circuit is running. The BT151-800R thyristor can handle as much as 800 volts and pass 7.5 amps of current continuously.

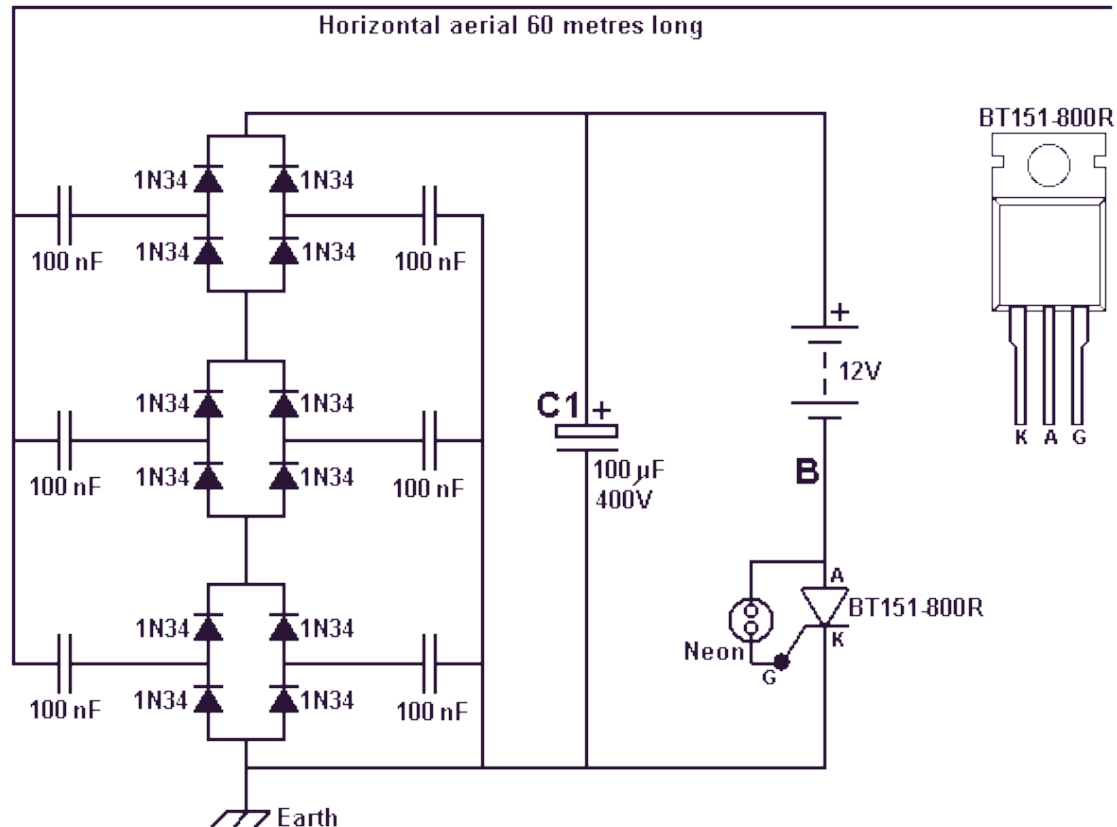

[Click here to download the full size of the above Circuit.](#)

An important point to note is that the power available from this circuit increases with additional aerials. With two aerials connected, the power is doubled and with three aerials the power is tripled. That is, each additional aerial provides as much power as the first aerial did and there does not appear to be any limit to the number of aerials which can be connected. The suggestion is that the aerial is suspended between the eaves of a house and a nearby tree, but I don't know anybody who would be able to do that. The longer the aerial or the greater the number of aerials connected, the greater the charging power available. The aerial wire should be not less than 0.5 mm in diameter and it needs to be insulated from its supports ? plastic cord can be used for that. The RF antenna connected to a circuit configured to convert the RF signals to Direct Current. The radio frequency signals received by the antenna are transmitted to two leads, one being rectified to produce positive voltage and the other rectified to produce negative voltage. The positive voltage lead is connected directly to a positive output line and the negative voltage lead is connected directly to a negative output line. The positive output line is connected to a pair of bus lines through a first pair of capacitors, while the negative output line is connected to the pair of bus lines by a second pair of capacitors. Placed between the first bus line...

## Simple self-powered circuit

Published: 2012/9/16 21:46:00 Author: Ecco | Keyword: simple self-powered | From: SeekIC

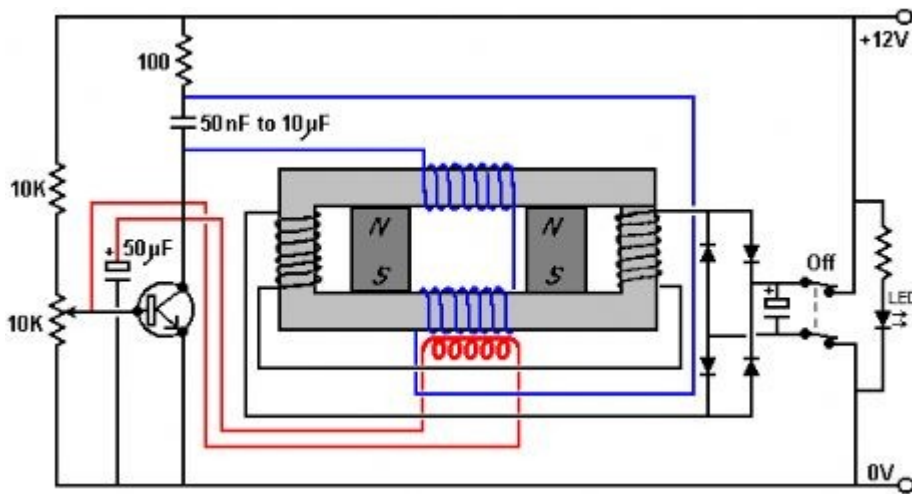

This simple circuit is started running by connecting a twelve volt battery across the terminals, causing the large diameter Light-Emitting Diode to light up. When the battery is removed, the LED stays lit up because the circuit has become self-powering. While, at this scale, this is not a particularly useful project, it is an interesting one because conventional science says that it is quite impossible to do this.

### Reprinted Url Of This Article:

[http://www.seekic.com/circuit\\_diagram/Power\\_Supply\\_Circuit/Simple\\_self\\_powered\\_circuit.html](http://www.seekic.com/circuit_diagram/Power_Supply_Circuit/Simple_self_powered_circuit.html)

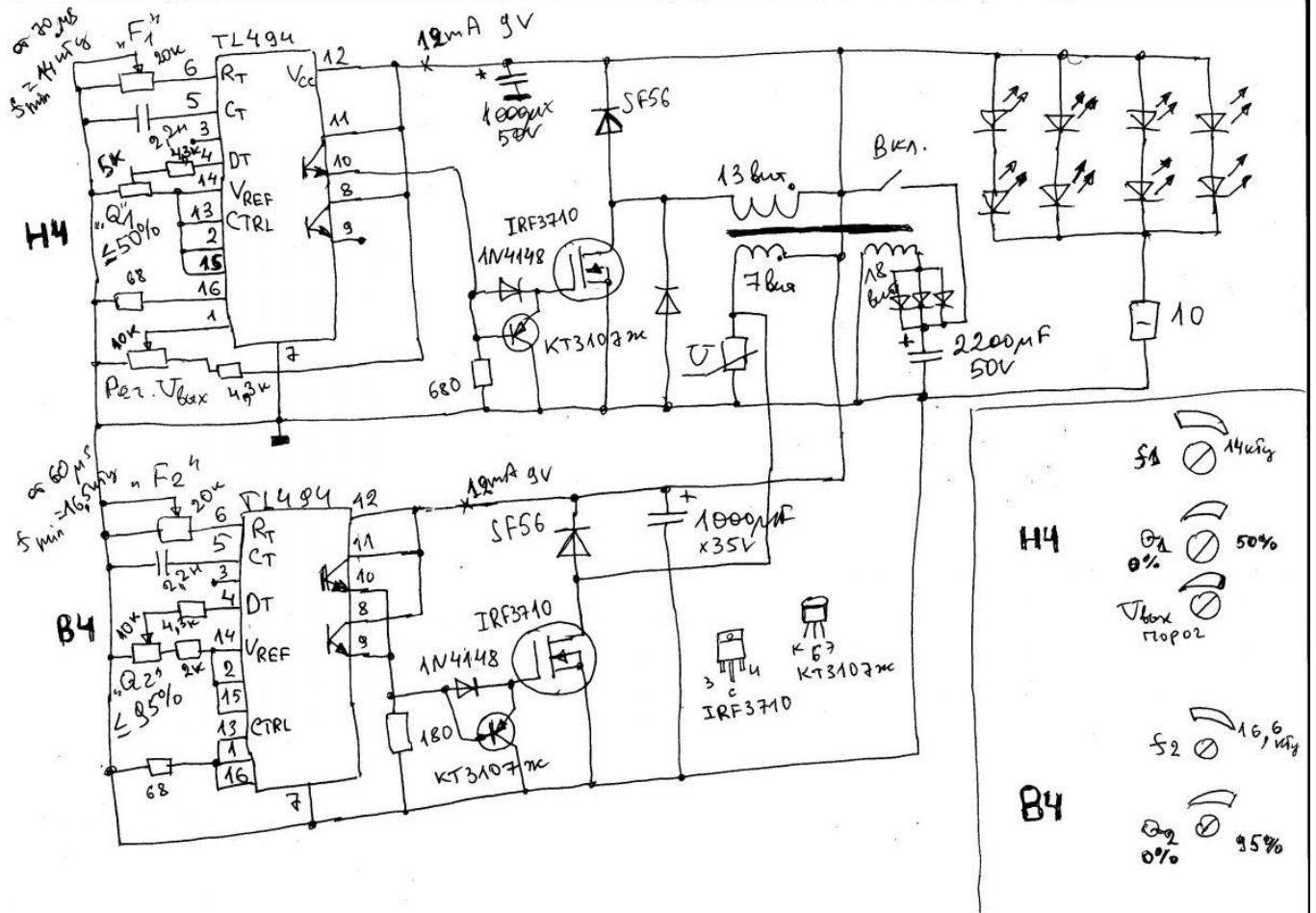
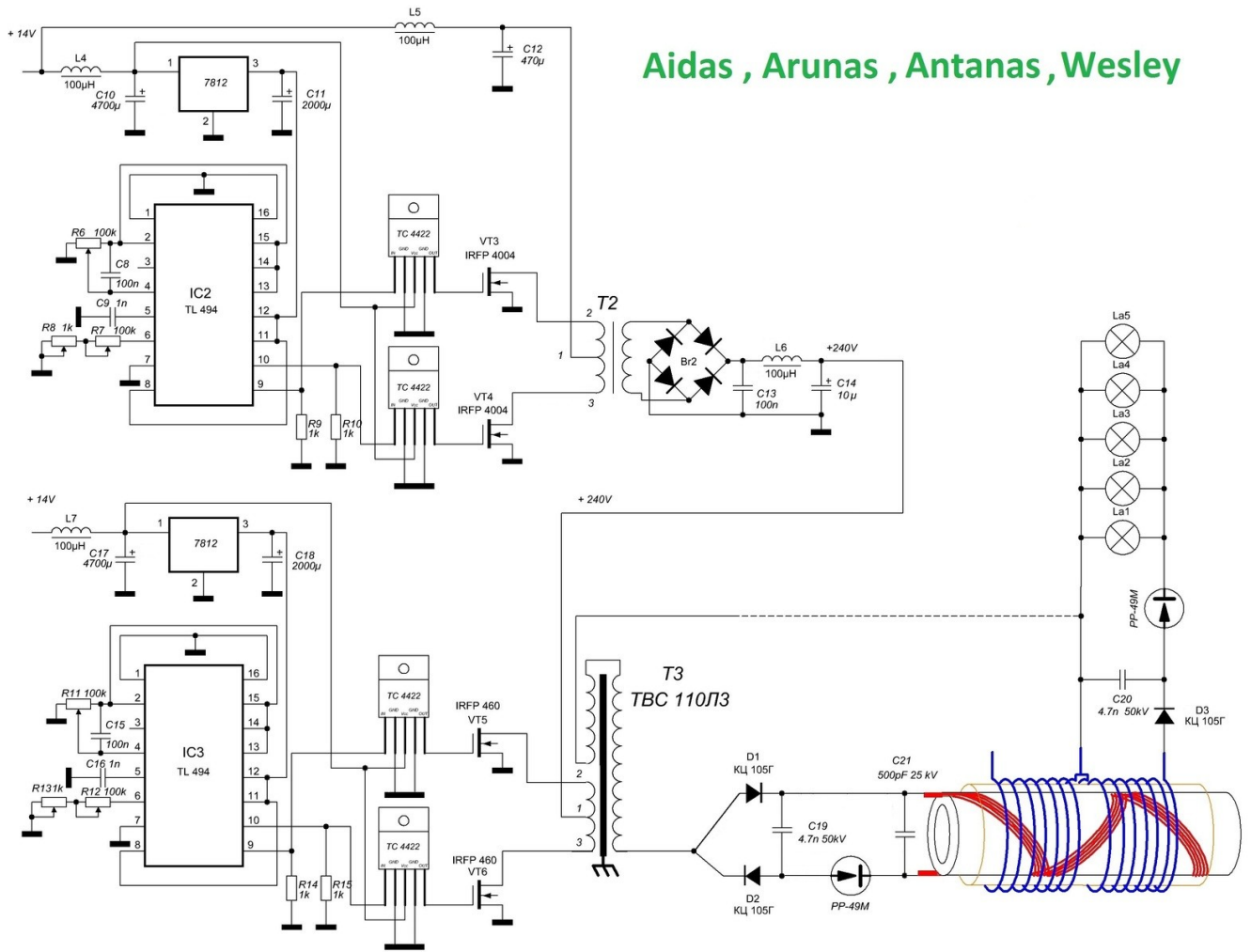



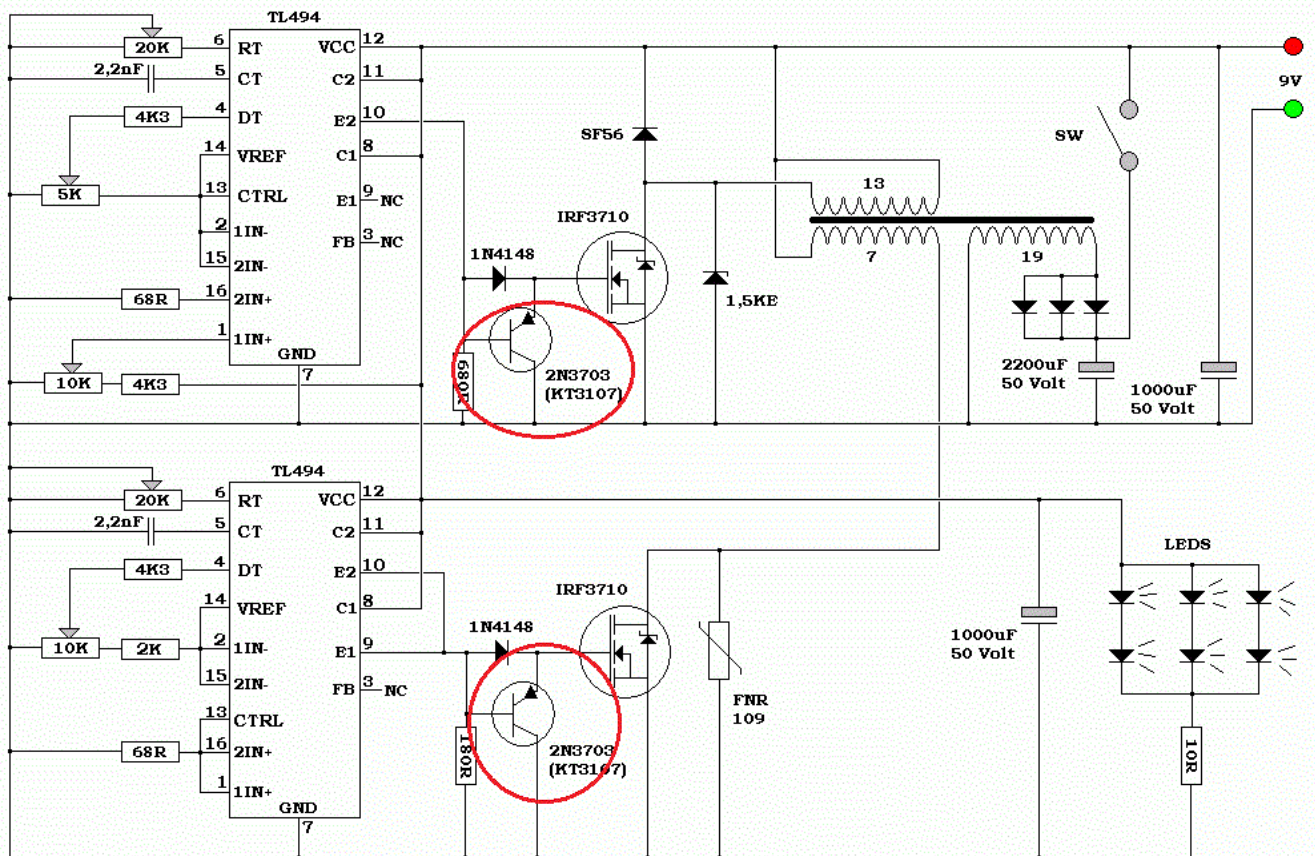

## OPENING

Open the effect of electricity generation on the basis of Faraday's electromagnetic induction. It allows through the use of ferromagnetic materials and a special magnetic field topology in the system to receive the excess energy of the magnetic field and convert it into usable electricity in unlimited amounts. Since 1831 a. Michael Faraday discovered the law of electromagnetic induction, no significant additions have been made to it. In particular, all the magnetic fields of magnetic circuits considered rigidly connected with wires like a simply connected system. For example, in the simplest case, the magnetization of ferromagnetic thought that everything is linked to the current magnetic circuit, winding magnetization. However, in the simplest case, a magnetic circuit consisting of two or three ferromagnetic volumes separated by nonmagnetic gap may occur magnetic fields do not form a flux coil magnetization is closed loop with current.

The theory of operation of electrical current source (electricity) to create a magnetic field is determined by the energy of the magnetic field through the coils of the magnetizing coil, plus the loss in the wires and hardware. The work of the current source is determined by the formula:

Eventually the work of the current source, the cost of electricity to create a magnetic field in the magnetic circuit is equal to the energy of the magnetic field through the coil with current. Thus, the energy of the magnetic field system, which is shorted out the turns of the magnetizing coil does not affect the setting of current in the coil and does not require for their formation cost of electricity from the power source, battery, generator, and so forth. For example, if we magnetize the iron (ferromagnetic) bar and next arrange another by separating it with a small air gap, the second bar magnet and magnetized, but apart from the total magnetic field arises around the bars of the second bar their magnetic field only closed around him and does not participate in the magnetic interaction between the two ferromagnetic volume. This magnetic field I called secondary. This field has no connection with the inductive coil magnetization in the first iron bar, and most importantly does not require on their education no electricity from the magnetization power supply. The secondary magnetic field has a certain energy which can be converted into useful energy. To do this, when demagnetization (turned off, decreases the current in the coil on the ground rod) on the second ferromagnetic volume (rod, bar) is removable special winding, which is connected to the load only when the demagnetization (not involved in the magnetization). Thus, all of the energy of the secondary magnetic field can be transformed into a series of additional useful energy.

The amount of iron (ferromagnetic) rods in the magnetic circuit can be infinite, under certain conditions. In some ferromagnetic means magnetic interactions can be extended to infinity. For example, domains turn in magnetodielectrics, fluctuations elektromagnitikov powders of ferromagnetic material.

In such systems, most of the energy of the magnetic field of the magnetic circuit has no direct connection with the inductive magnetizing source. There is a huge amount of magnetic circuits, where you can get a secondary magnetic field, magnetizing coil is closed. This secondary magnetic energy can be used to generate electricity. Dozens of devices for the generation of electricity on the pulse and alternating current, including directly sinusoidal current at power frequency: 50: 60Hz. It is sufficient to conventional transformer iron wires and power electronics components.

Outdoor physical effect of energy generation, I as the author called Transgeneratsiye electricity. Effect brilliantly confirmed in a simple experiment, and has been thoroughly studied in the research on different types of ferromagnetic materials and magnetic circuits.

Now there is the international patenting of inventions based on this effect in many countries. Patented a method of power generation and a number of devices based on this method.

From the point of view of theoretical physics the effect of generation is possible due to the special nature of quantum ferromagnetikov. The magnetic field is formed by the electron spin - magnetic moments of electrons. Unlike conventional electron currents in the wires back absolutely not responsive to the so-called zero inductive impedance (resistance). When magnetized to it only needs to exert a magnetic field, not the electric power in the coils with electric current. In magnetic systems with a secondary magnetic field arises (generated by) the additional energy of the magnetic field, which can be easily converted into additional useful energy in its purest form.

In systems with a secondary magnetic field, there is also a secondary electric field together form a vector Poynting energy flow directed into the ferromagnetic volume from the surrounding physical continuum, rather than from the magnetization coil wires.

Transgeneratsiya electricity can generate clean electricity from ferromagnets in unlimited quantities. Ferromagnet plays the role of the quantum of the electromagnetic pump pumping energy from the physical continuum and converts it due to the Faraday effect in electricity.

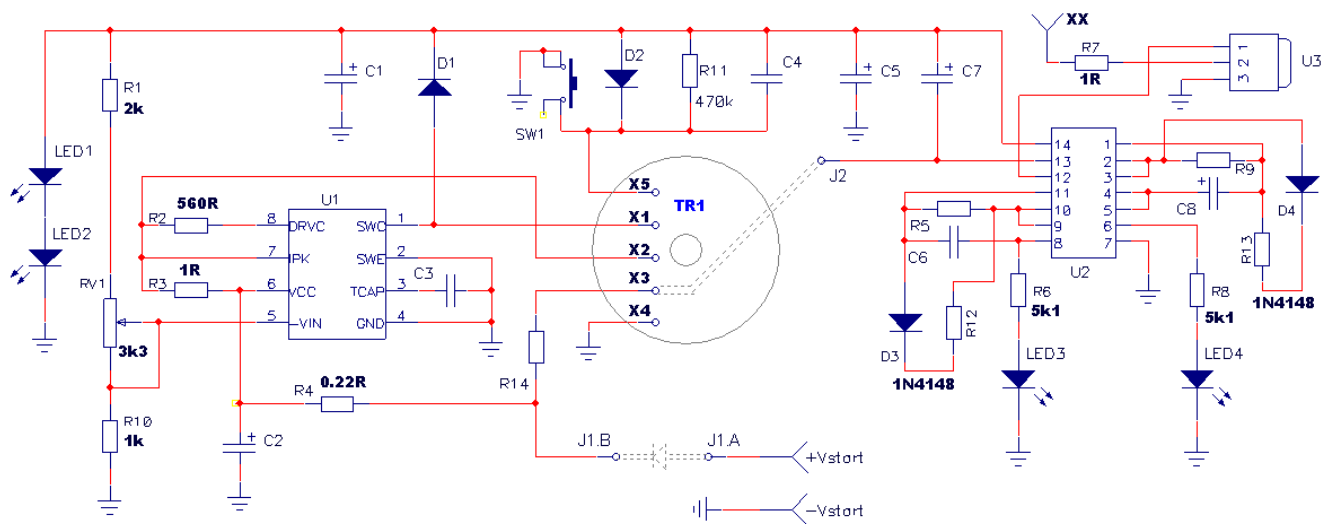

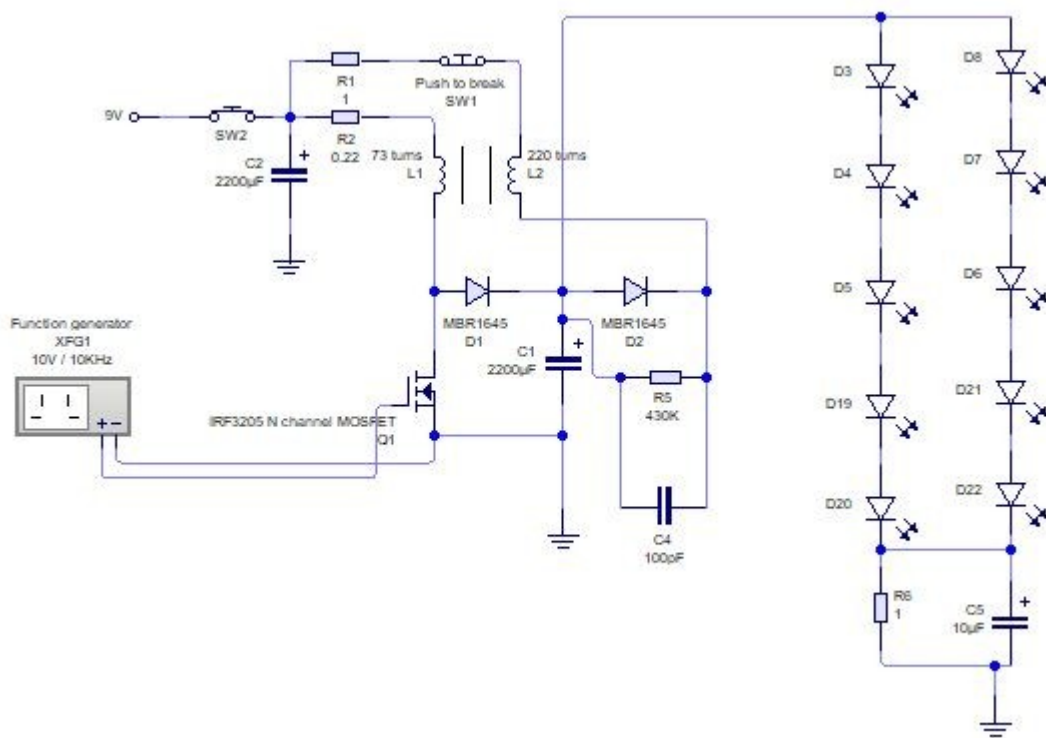

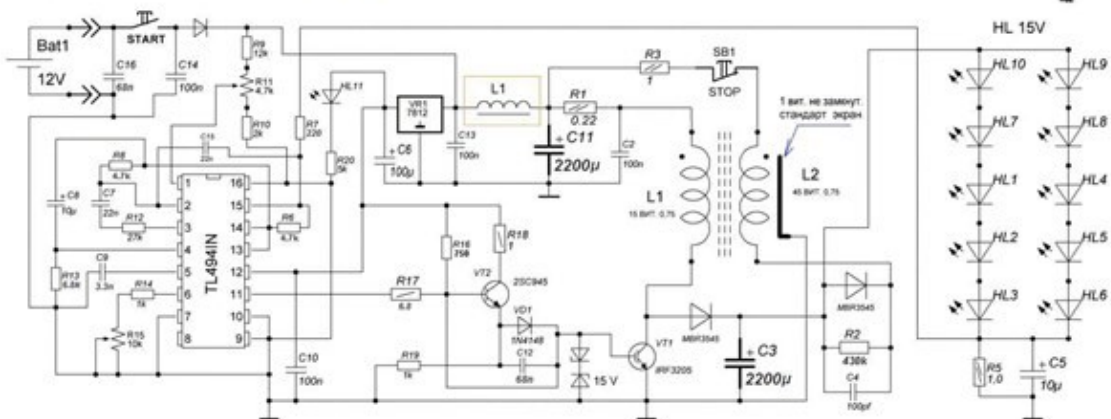

Ажыра0083 

Фонарь 30W 

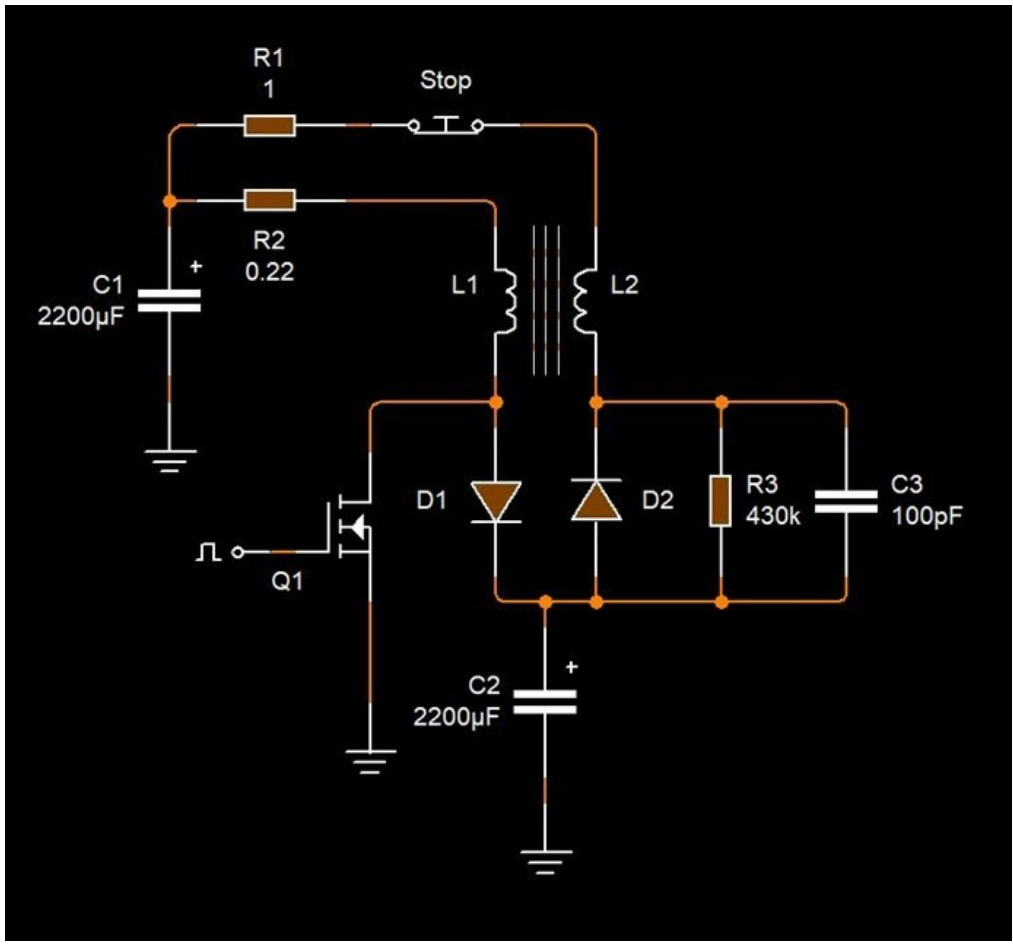



Акула 0083 

Фонарь 30W 

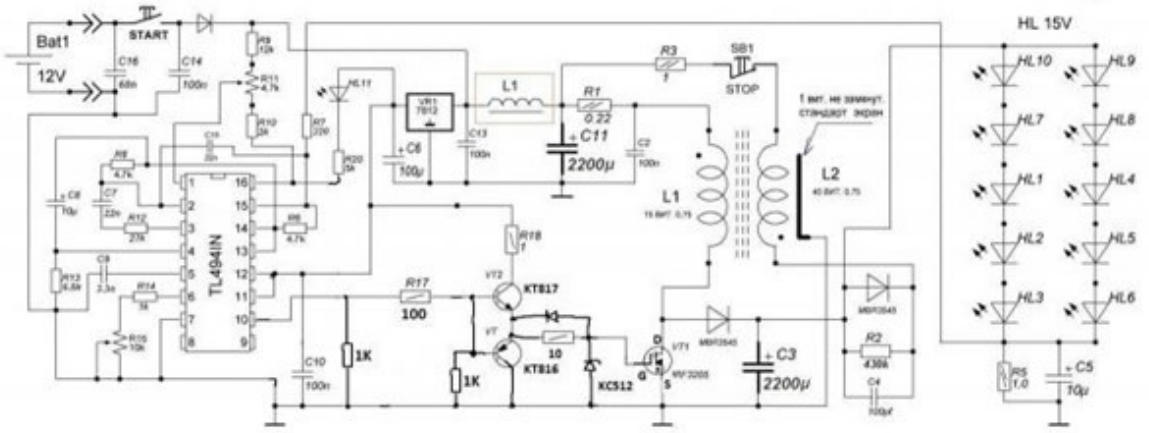

Акула0083



Фонарь 60W



Edited by T-1000

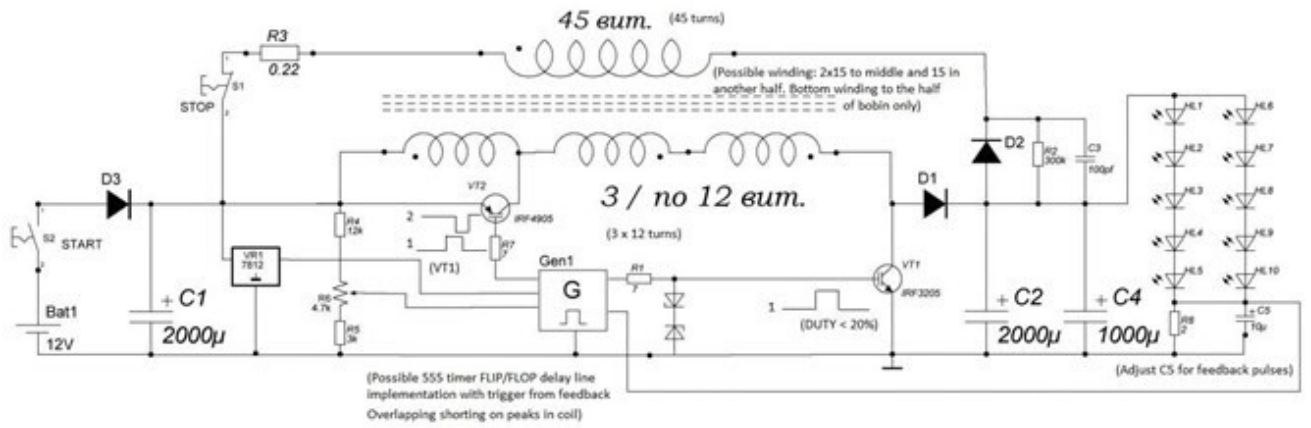

Акула0083



Фонарь 60W

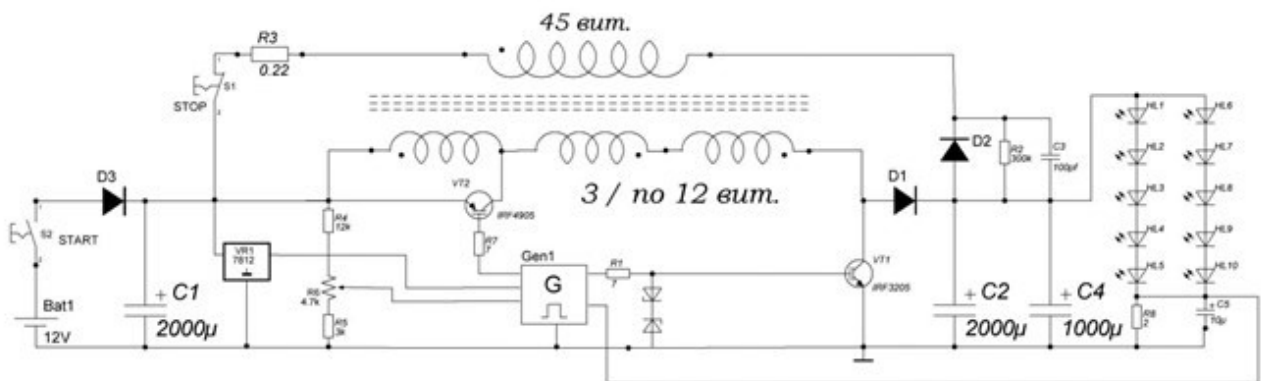
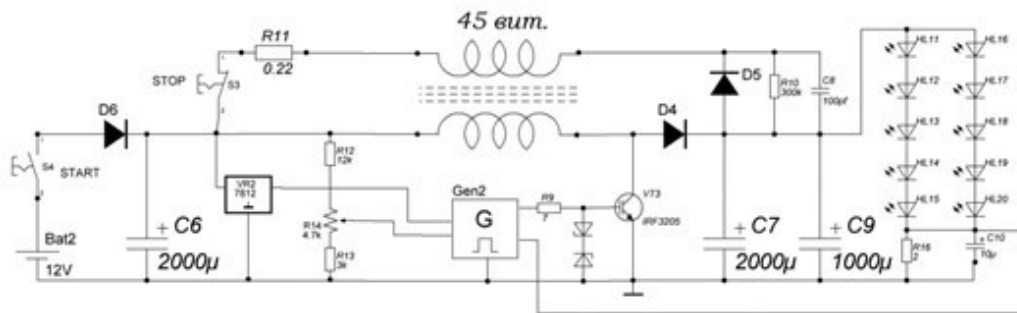

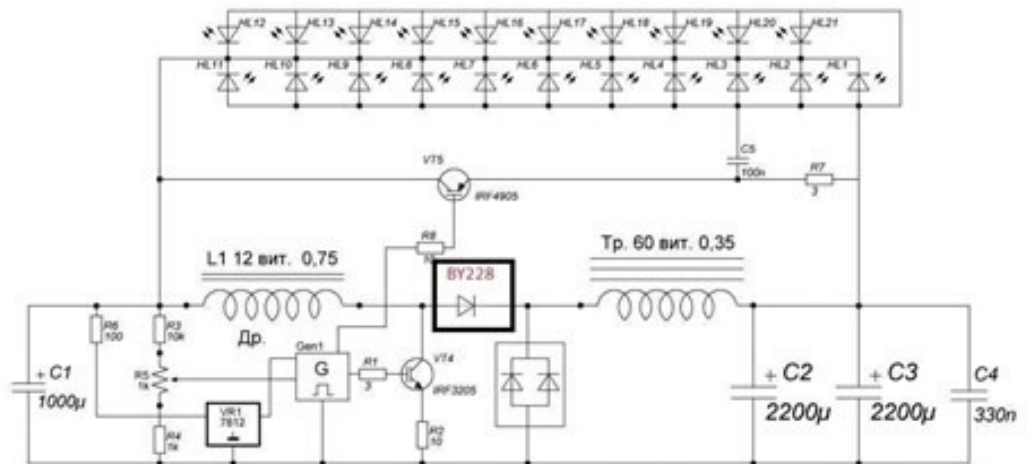
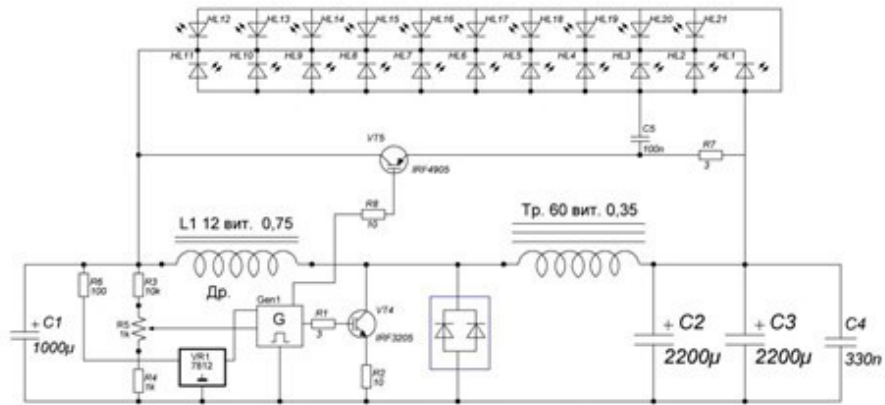

Акула0083  схема базовая для проверки ферритов.

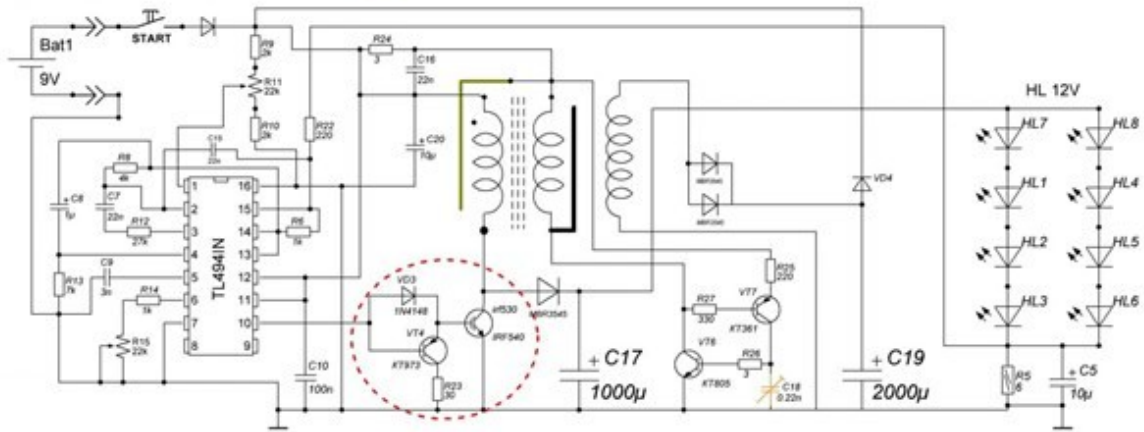

заккрытие 20-27-35нс

Акула0083  схема базовая.

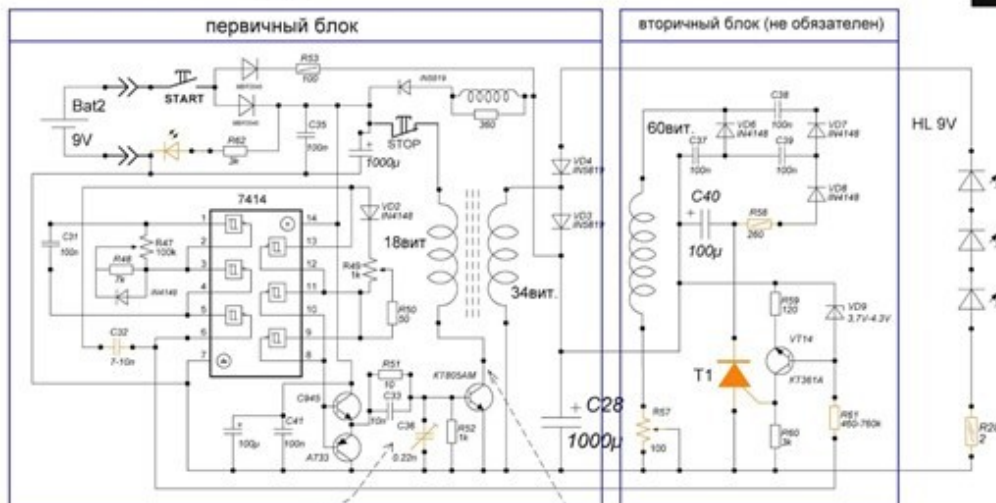

AKULA0083

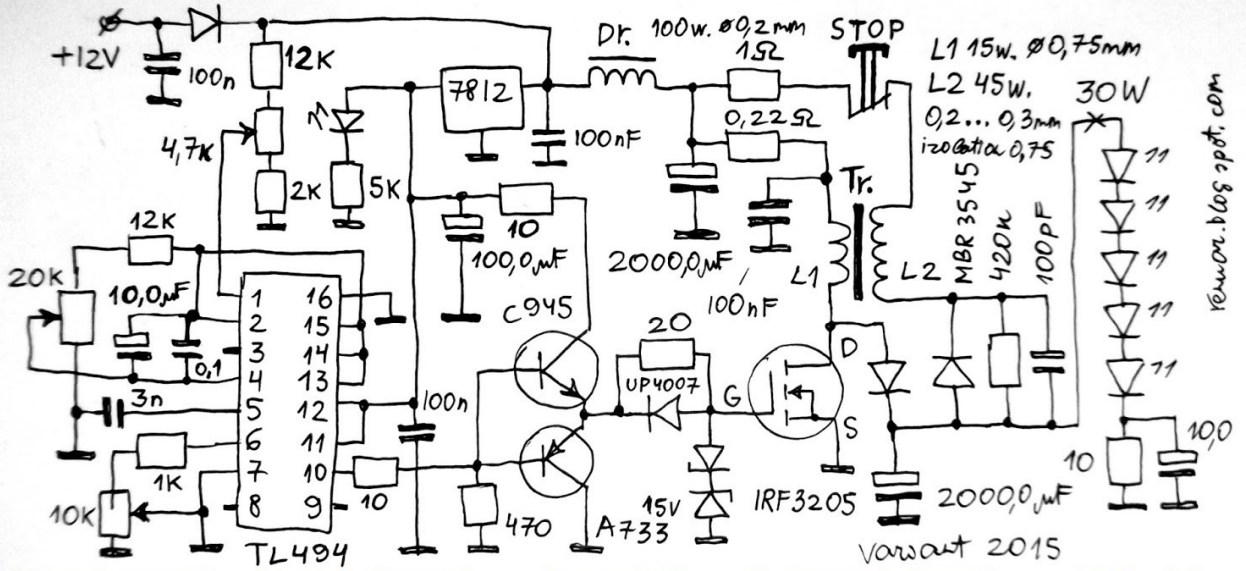

# FREE ENERGY

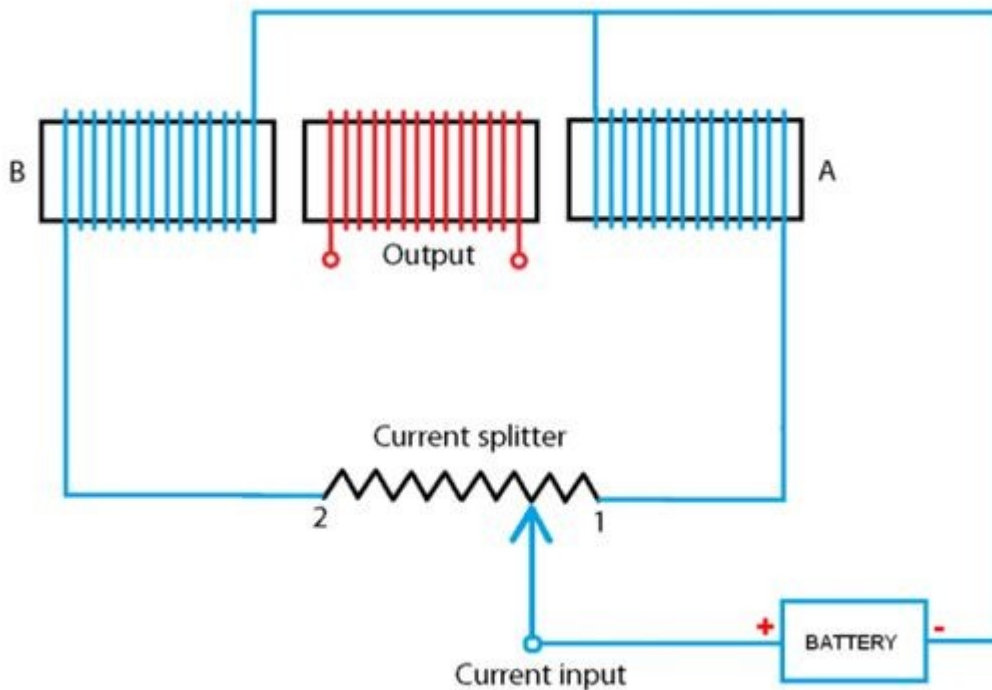
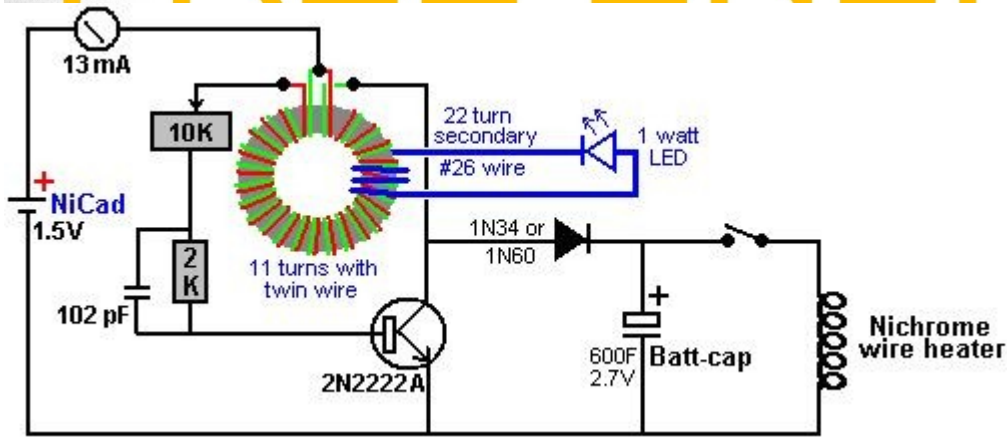

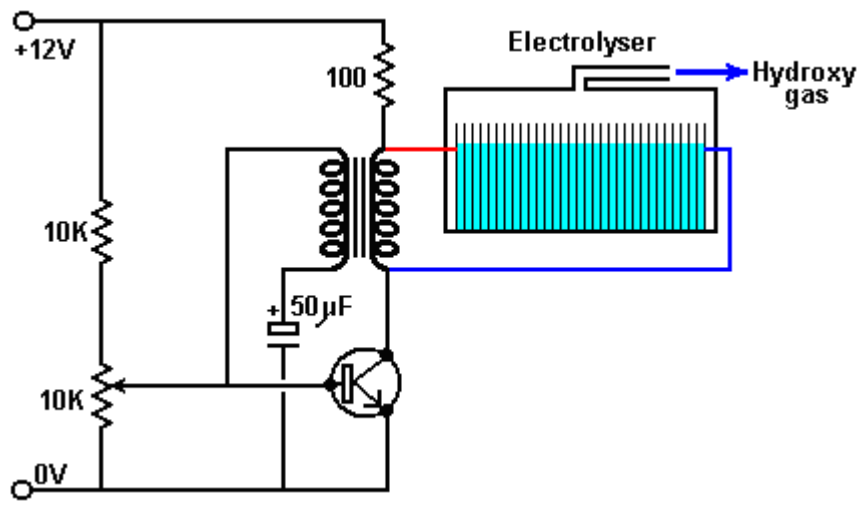
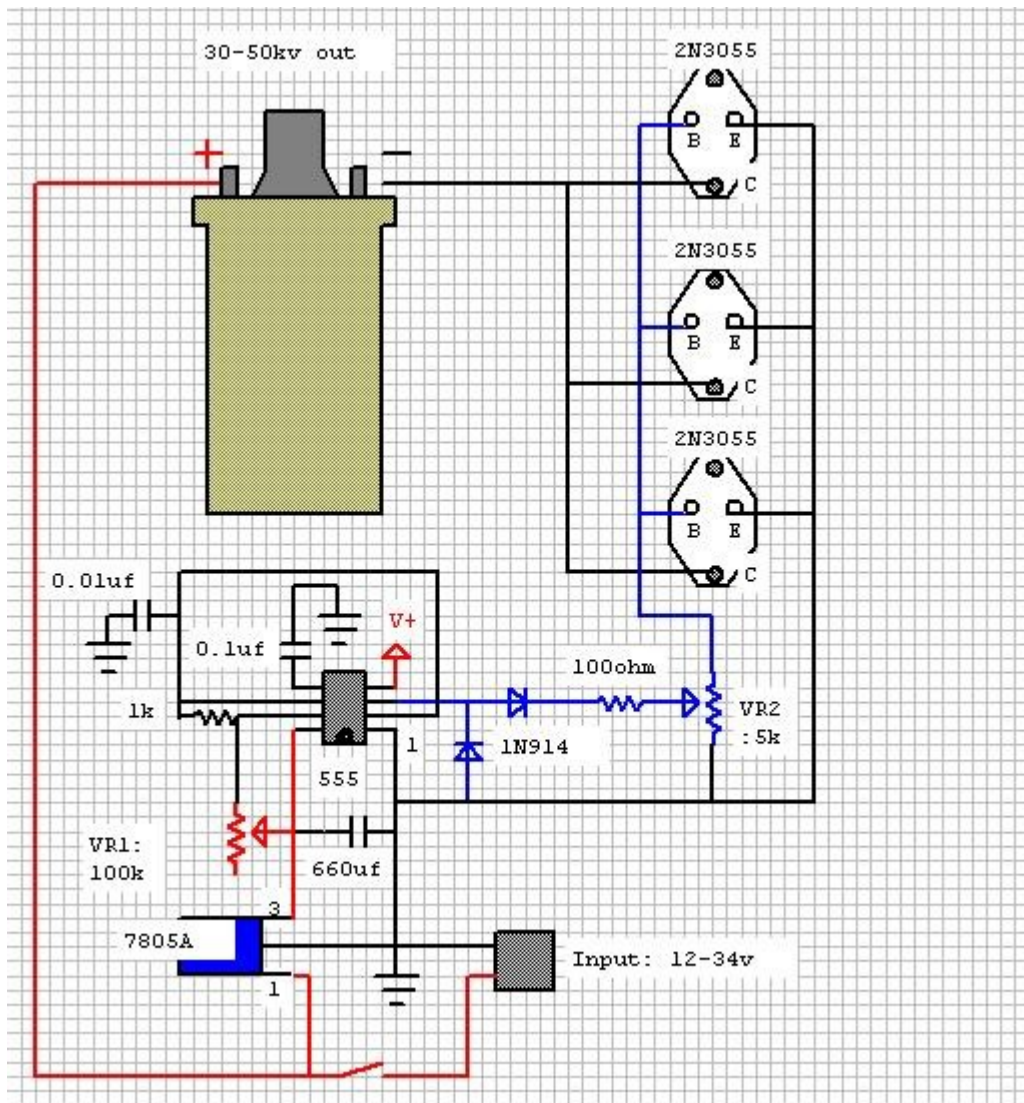



In a push pull signal amp the power supply is connected to the center-tap of the transformer (An Ignition coil is like and can be used as a high voltage transformer) and a tube is connected to both the upper and lower end of the center-tapped primary. This allows the tubes to conduct on alternate cycles (Alternating current or AC) of the input waveform.

So in short – Tesla connected the antenna (an electrical device which converts electric radio waves into current – i.e. an infinitely free power supply) to the center-tap of the ignition coil of the Pierce Arrow. 12 vacuum tubes were then wired (connected) together in parallel and connected to the ignition coil. In this circuit, Tesla amplified the very weak radio wave signal and produced a very high voltage output. Enough to power the 80 HP AC electric motor for a full week, often at speeds of up to 90 mph.

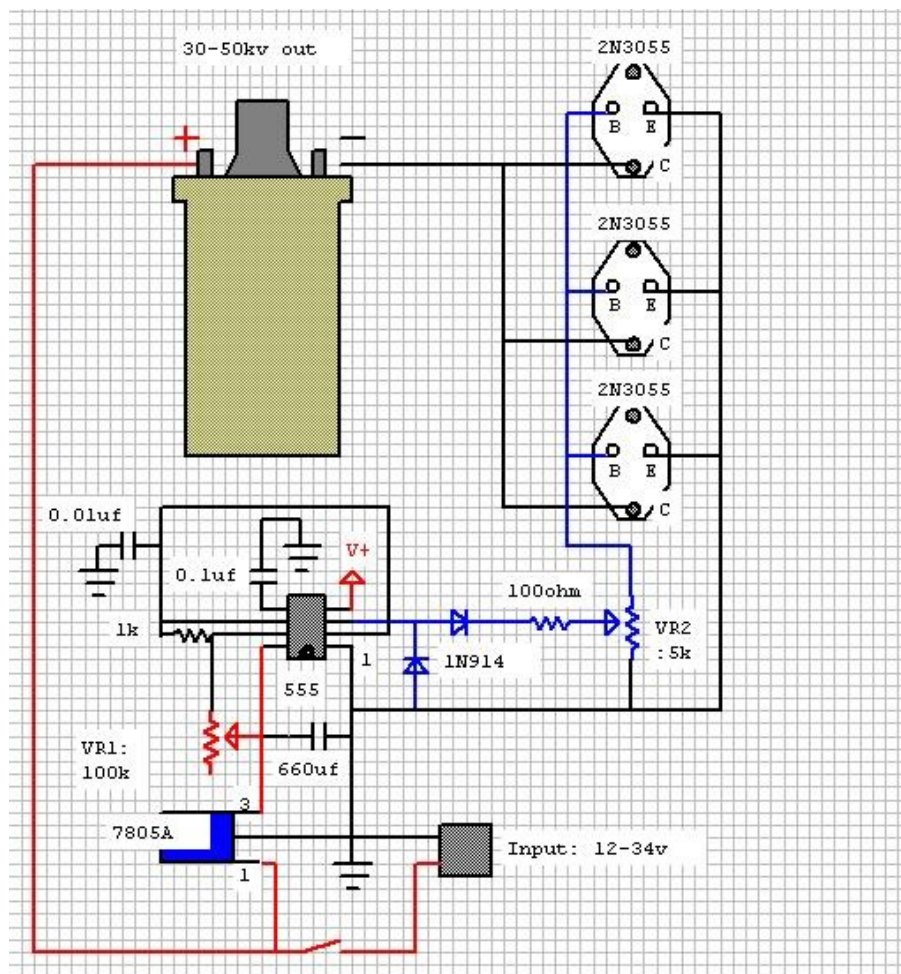

HOW CAN THE STATIC ENERGY PRODUCED BY THE CABLE BE CONVERTED INTO A USABLE FORM?

The only practical method I have found in the past was to charge a battery. My ionic diode component might be another way to do the conversion. I will run some tests when I get the time..

The static electricity generated can be used to charge a battery using nothing but a spark plug, a coil and a capacitor, but the process is only 15-20% efficient using conventional diodes. An efficient voltage controller must be used to keep your battery from overcharging. The circuit is needed to convert static charge into low voltage to charge batteries. The least expensive design uses a spark plug, an old automotive coil, a .001, 3 to 20kv capacitor and a ground rod.

Thus far, I have devised two methods. The first is simple and inexpensive but only 15-20% efficient. It simply involves breaking the current into pulses with a spark gap, and then transforming the voltage down and current up with a transformer and increasing the pulse duration with a capacitor in parallel.

The second method will use a micro-processor to monitor voltage and current. The impedance is then adjusted to make the charging current as smooth as possible. This circuit can also easily protect a battery from overcharging. Bill Alek's controller might be the perfect solution for the task.

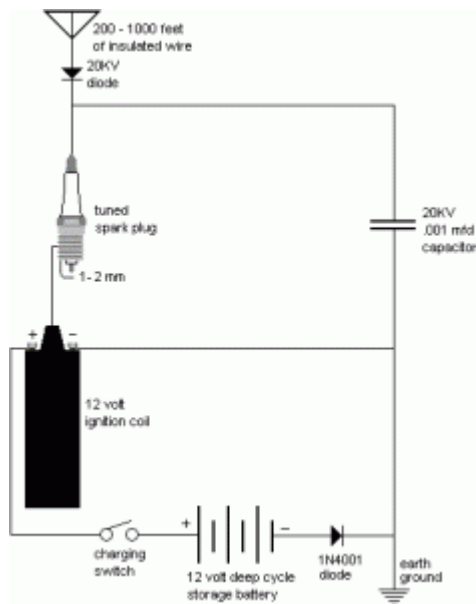

The electret effect is more important than you realize. Any ordinary antenna will collect charge, but without the electret effect, most of it is dissipated before it can be tapped. The electric field created by the electret effect not only attracts the charge from the air, but then it traps it in the conductor. This effect will also be produced even in a vacuum.

Virtually all insulated cable exhibits some degree of the electret effect, which the wire manufacturers consider undesirable. Treating the coax will increase the electret effect at least 10 times. Treatment cost is negligible. Obviously, the treatment process is the essential piece to receiving enough energy to be useful. Teflon tape can be dangled from a cable and wonderful results can be obtained. In a thunderstorm, using an ordinary 400-foot cable with Teflon tape has produced a continuous arc eight feet long. Essentially, what you have is a type of Van De Graff Generator. I have not witnessed this myself but this appears to be possible because a lightning discharge releases energy that has been estimated to be in the billion watt range.

## CONDITIONING THE CABLE

Buy cheap coax RF cable, that has a center wire and a shield cylindrical wire. Then cut off the outer plastic skin and put the whole cable into your oven and heat it up to about 100 degrees Celsius or more, so that the internal plastic insulation almost begins to melt.

Then apply from a D.C. high voltage source around 30 kilovolts or maybe a little less, so that there will be no arc-over yet inside the cable. Then let the cable cool down slowly again, but still apply the high voltage D.C.

When the cable has come down to room temperature again, it will be a pretty good electret!

Now hang this cable in the air and the outer layer of the shield metal (which does not have any plastic isolation skin anymore), will now attract lots of free ionized electrons from the air and charge up the outer shield metal of the cable. This way you can collect lots of more charges as before and have a much higher electrical output from this cable.

Hope this helps  
Regards, Stefan

The electret effect is a problem in the manufacturing of coaxial cable. This problem arises from the process used to make insulated wire; an unwanted electret effect is created. Engineers work very hard to reduce the effect but are unable to completely eliminate it. What I am saying is that all insulated wire

exhibits some electret effect. The engineers go to great lengths to minimize it. The treatment as suggested by Stefan Hartmann should increase the electret effect of the cable at least 100 times, and with some cable, as much as 1000 times (depending on how hard the engineers worked). The electret effect is present wherever plastic is in contact with a conductor. It is much better to use unshielded cable and it is cheaper as well. If you do use shielded cable, it might not draw as much radiant energy. To begin your radiant energy experiments string out a 300-foot length of ordinary coax cable and do not connect the other end to anything. Use the conversion circuit in this article to convert your collected charge into electrical power. When you ground this circuit do not use the one that is connected to the electric companies meter. If you do not get at least a couple of pops per minute from your spark plug you will need to condition your cable as explained by Stefan Hartmann. Tying a bunch of 2-foot pieces of Teflon tape to your cable will also increase its draw power.

Virtually any insulated wire has a small electric field surrounding it that attracts positively charged air molecules (called ions) to itself. This charged moving air mass induces a negative charge of static electricity that builds up in the cable conductor. Under most circumstances, the conductor in a cable is connected to a circuit and the current is absorbed without notice. Nevertheless, if the conductor is connected to a spark plug (whose threads are grounded) it will produce an electric arc across the spark gap each time the voltage in the cable rises to the limit of the spark plug's gap. In some cases with a long piece of cable and some air current (wind), the spark gap will arc almost continuously. During a thunderstorm, Paul Clint reported to me that he once witnessed an eight feet long arc during a thunderstorm. A continuous arc or one that is eight feet long indicates to me that a substantial amount of power was being received. This means that a treated piece of insulated wire can be strung out on a fence and used to generate enough power to provide a home owner with all they need. It also means that it is possible to generate power in winds that have previously been considered worthless (3-4 mph).

#### HOW CAN A SMALL CABLE EXTRACT SO MUCH ENERGY FROM LITTLE OR NO AIR CURRENTS?

This is easily explained. The energy collected from the cable is not derived from charge collection as one might first think. It is derived from induction, as the positive ions in the air rush towards the cable. As you may or may not be aware, the earth's atmosphere is a gigantic capacitor. At its upper level, air molecules are constantly being ionized and then as the air circulates, the charge is eventually carried to the ground that has a negative charge with respect to the upper atmosphere.

Ham radio operators will certainly confirm that a coaxial cable strung out, as an antenna, will become highly charged, especially in wet, stormy weather. The accumulation of charged ions is not possible in a humid environment. Therefore, the power is derived through charge induction rather than from static charge. This is clearly demonstrated from the fact that the power generated is directly proportional to the speed of the wind rather than the square of the speed.

#### STILL, THE WIRE HARDLY INTERSECTS ANY OF THE WIND. HOW CAN A LITTLE WIRE COLLECT SO MUCH?

The cross section of the wind from which power is collected is much larger than you might think. Remember that the electret effect creates an electric field, which attracts charged air molecules as a magnet attracts iron. The cross section of this field can be as great as 2 feet, so a 100-foot cable can intersect as much wind as a 16-foot diameter airfoil.

#### HAVE YOU MEASURED THE CABLE POWER OUTPUT?

Measurement of the output of the cable is not a simple process. The output varies over several orders of magnitude for voltage, current, frequency, and is well beyond the capability of simple measuring devices. Because of this fact, I have devised a couple of indirect methods to measure output. In the first of these, I have connected a spark plug between a cable and ground so that whenever the voltage builds up to the arc-over value, a pulse of current is generated that can be counted. This method can be termed no more than a rough estimate because the shape and duration of the pulse still varies over a substantial range. Analysis of the pulses will eventually allow us to use an average and thus devise a formula that will give a close approximation of the power output.

The second method is simple and if done properly, very accurate. We simply place a resistive heating element between the generator and ground and then into a bucket of water. The output is then measured

by the change in temperature of the water. Neither of the two methods takes into account the losses of the charging circuit, battery, or inverter, etc...

#### DOES THE ELECTRET EFFECT WEAR OUT OR DISSIPATE OVER TIME?

The question as to whether the electret effect wears out is not a simple one to answer. It is clearly being used in a way that is unique. The fact of the matter is that, in general, the electret effect is unwanted, and engineers are normally working to prevent or eliminate it. The fact that they have to work very hard to do so is an indication that it is stable. Thus, the best answer I can give is that it does not wear out in the short term (years).

#### HOW CAN I DETERMINE IF THE CABLE WILL PRODUCE MORE POWER FOR ITS COST THAN I WOULD HAVE TO PAY THE UTILITY COMPANY?

Again, this can only be done over a long time-period because it is dependant on wind, location, humidity and possibly other lesser, undetermined factors.

#### HOW DOES HUMIDITY AFFECT CABLE OPERATION?

Ham radio operators have reported that static charge builds up on their antennas more often and more intensely in times of high humidity, rain, or snow. The technical literature reports that most atmospheric charge is carried by aerosol particles of dust or water that collect hundreds, thousands, and sometimes tens of thousands of units of charge. As they collect more and more charge, these particles migrate toward the earth's surface and constitute a major component of the fair weather current.

#### HAVE YOU TESTED CABLE GENERATOR IN OTHER CONFIGURATIONS SUCH AS A SPIRAL, COIL, GRID, OR VERTICAL MODE?

Optimum results are obtained by suspended an insulated cable between 5 to 15 feet above the ground in a horizontal straight line. Any deviation from this will reduce the output of the cable generator.

You must use an insulated cable that is strung out horizontally. For it to function properly there should be a swag to it.

Please see... <https://www.nuenergy.org/the-surgingsounds-of-the-universe/>

If you see that the cable is physically vibrating you will know that it is set up properly. Any wire will vibrate but it needs to be electrically insulated and possess the electret effect to generate self charge. There is more than just wind that is involved. The cable will vibrate sometimes with only the slightest breeze. As you can see here there is a real energy source that is waiting to be harnessed. Essentially, we are utilizing the induction from a moving ion field. This is why a cable can be seen to physically vibrate. Where the seat of kinetic activity actually originates from I do not know. What I do know for certain is that energy is present in the system.

#### WILL A BARE WIRE GENERATE A CHARGE?

Bare wire will not generate a charge. The electret effect has to be present.

Please see... <http://www.esdjournal.com/static/shower/shower.html>

#### HAS ANYONE MEASURED THE ION DENSITY OF THE ATMOSPHERE?

Yes, the average is 3000 ions per cubic meter. The figure is subject to stupendous variations of many orders of magnitude as shown by this quote from "Atmospheric Electricity in the Planetary Boundary Layer" by William A. Hoppel, R.V. Anderson and John C. Willet. "Most atmospheric processes are interrelated and cannot be studied in isolation, but it is possible to identify one or two dominant influences. In the case of Atmospheric electricity in the Planetary Boundary Layer, however, separating the various causes and their effects can be extremely difficult. In fact, this field may be unique with respect to its sensitivity to many disparate phenomena spanning a tremendous range of scales in both space and time. For example, locally produced turbulent fluctuations in space-charge density have an effect roughly comparable in magnitude to that of changes in the global thunderstorm activity on electric-field variations within the Planetary Boundary Layer."

THE ION DENSITY DOES NOT APPEAR TO PROVIDE ENOUGH CHARGE TO ACCOUNT FOR THE CURRENT GENERATED BY THE CABLE. ARE THERE OTHER SOURCES OF ENERGY CONTRIBUTING TO THE CURRENT?

Both the electric field of the earth (typically 100-200 volts) and that of the cable produce an effect called the induction charging mechanism. This is a physical process for particle charging involving the collision of pairs of particles in an ambient electric field. Electric charge induced on particles surface by the ambient electric field is made available for transfer when the two particles come into contact. A subsequent differential particle motion that is influenced by gravity is postulated to result in large scale charge separation. The specific role of induction charging in the electrification of thunderclouds has not been resolved.

Another effect that is unquestionably effecting the cable is the double layer effect. On the surface of a substance a layer of electric dipoles whose axes have an average orientation normal to the surface, double layers may appear on the interface of a solid and gas, liquid and gas, liquid and liquid, etc. They arise whenever media with different electron affinities (forces of attraction, or work function) are contiguous, and if dipoles are available. A net potential difference, the electrokinetic potential exists across the double layer. This effect is demonstrated in the super capacitor. Therefore, our cable acts like a super capacitor of high farads.

Yet, another source of atmospheric charge collected by the cable is due to aerosol charges. These particles of dust or water form dipoles and disproportionately collect one charge or the other. Where ions carry only single or double units of charge, aerosols carry hundreds, to tens of thousands, of units of charge. The fact humidity is such an important factor in the output of the cable indicates that aerosols are an important source of the energy it collects.

WHAT ELSE WOULD BE NEEDED BESIDES A CABLE TO PROVIDE A GOOD ALTERNATE ELECTRICAL SOURCE FOR A HOME?

You would need a battery or bank of batteries, a charge controller, and a grid tied inverter.

Shop Related Products

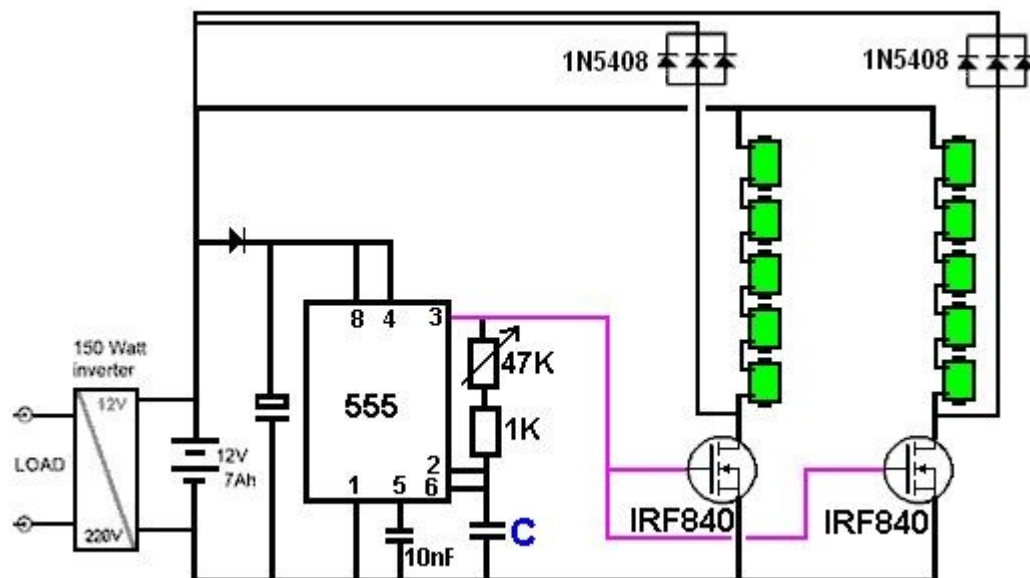

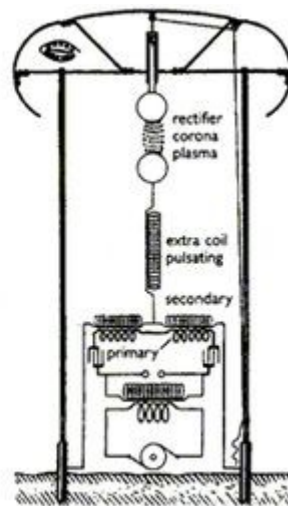
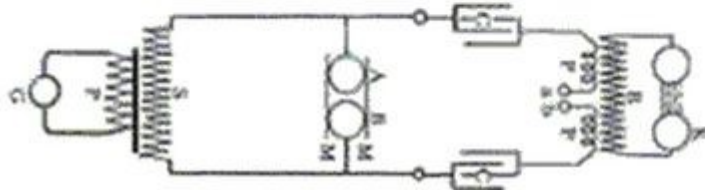
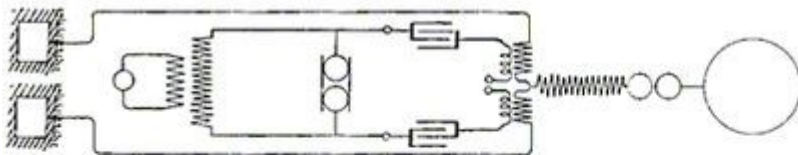
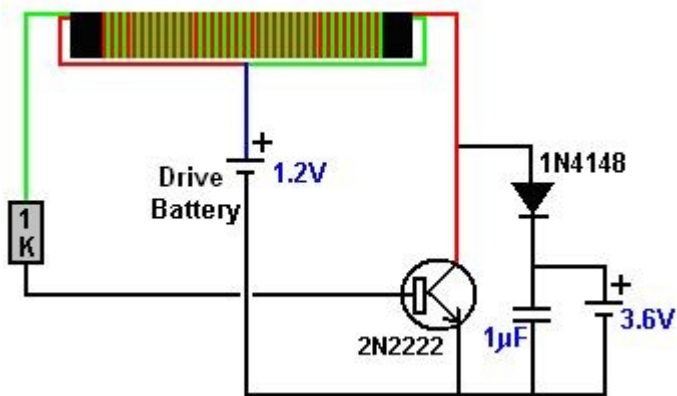

Possible schematics of the device

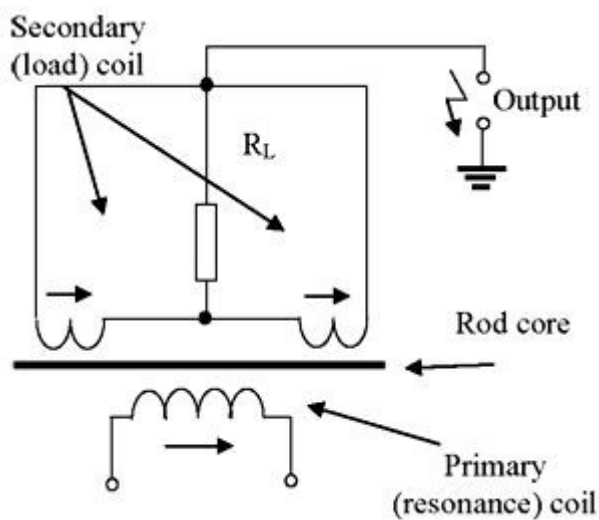
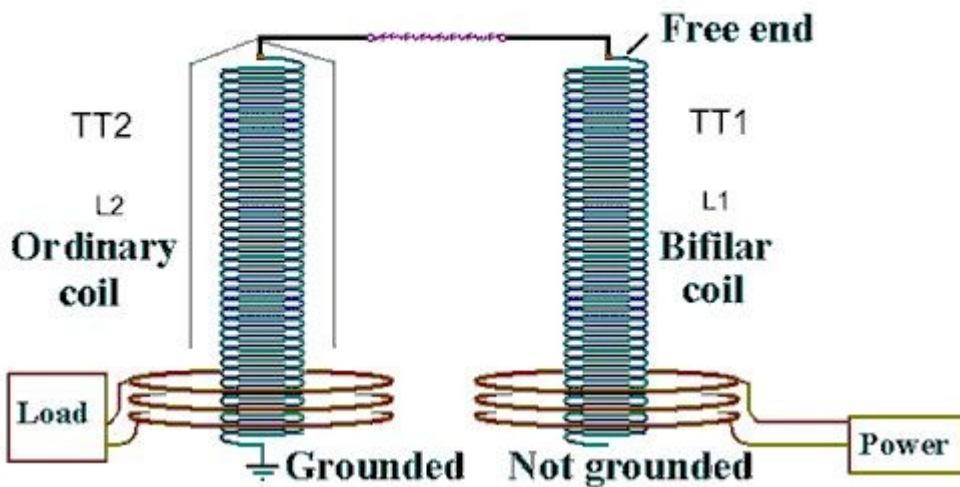

Free energy battery charger

Posted on Jan 15, 2013

Under: [Free Energy Circuits](#)

As the circuit operates, the three sets of diodes with their isolation capacitors, build up an increasing voltage on capacitor ?C1?. The voltage at point ?B? will also increase and be about twelve volts less than the voltage on capacitor ?C1?. Eventually, that voltage will rise high enough to cause a discharge through the tiny neon tube and that current pulse flows through the Gate connection ?G? of the thyristor, switching it on. Once switched on, the thyristor stays on until capacitor ?C1? has been discharged, after which, the thyristor switches off and the process starts all over again. The amount of power in these pulses is considerable and the thyristor gets quite warm when the circuit is running. The BT151-800R thyristor can handle as much as 800 volts and pass 7.5 amps of current continuously.

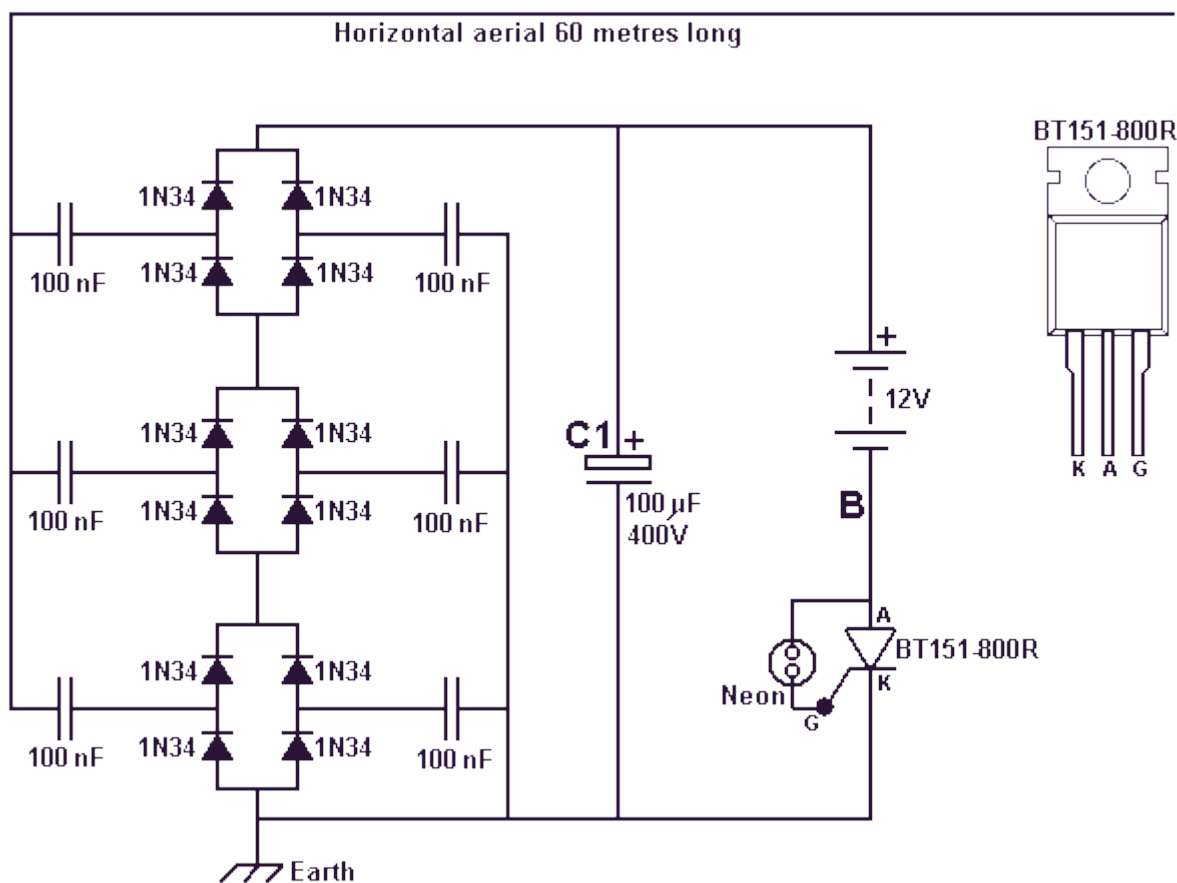

[Click here to download the full size of the above Circuit.](#)

An important point to note is that the power available from this circuit increases with additional aerials. With two aerials connected, the power is doubled and with three aerials the power is tripled. That is, each additional aerial provides as much power as the first aerial did and there does not appear to be any limit to the number of aerials which can be connected. The suggestion is that the aerial is suspended between the eaves of a house and a nearby tree, but I don't know anybody who would be able to do that. The longer the aerial or the greater the number of aerials connected, the greater the charging power available. The aerial wire should be not less than 0.5 mm in diameter and it needs to be insulated from it's supports ? plastic cord can be used for that. The RF antenna connected to a circuit configured to

convert the RF signals to Direct Current. The radio frequency signals received by the antenna are transmitted to two leads, one being rectified to produce positive voltage and the other rectified to produce negative voltage. The positive voltage lead is connected directly to a positive output line and the negative voltage lead is connected directly to a negative output line. The positive output line is connected to a pair of bus lines through a first pair of capacitors, while the negative output line is connected to the pair of bus lines by a second pair of capacitors. Placed between the first bus line...

