

The 150-watt Generator Goes Solid State

A free-energy developer who lives in South Africa and who prefers to remain anonymous, has very kindly shared the details of his compact self-powered generator so that you can build one if you choose to do so. His design has developed through several stages and reached 150 watts of self-powered output. He used an accurately made rotor with five magnets, spinning inside a ring of ten coils:

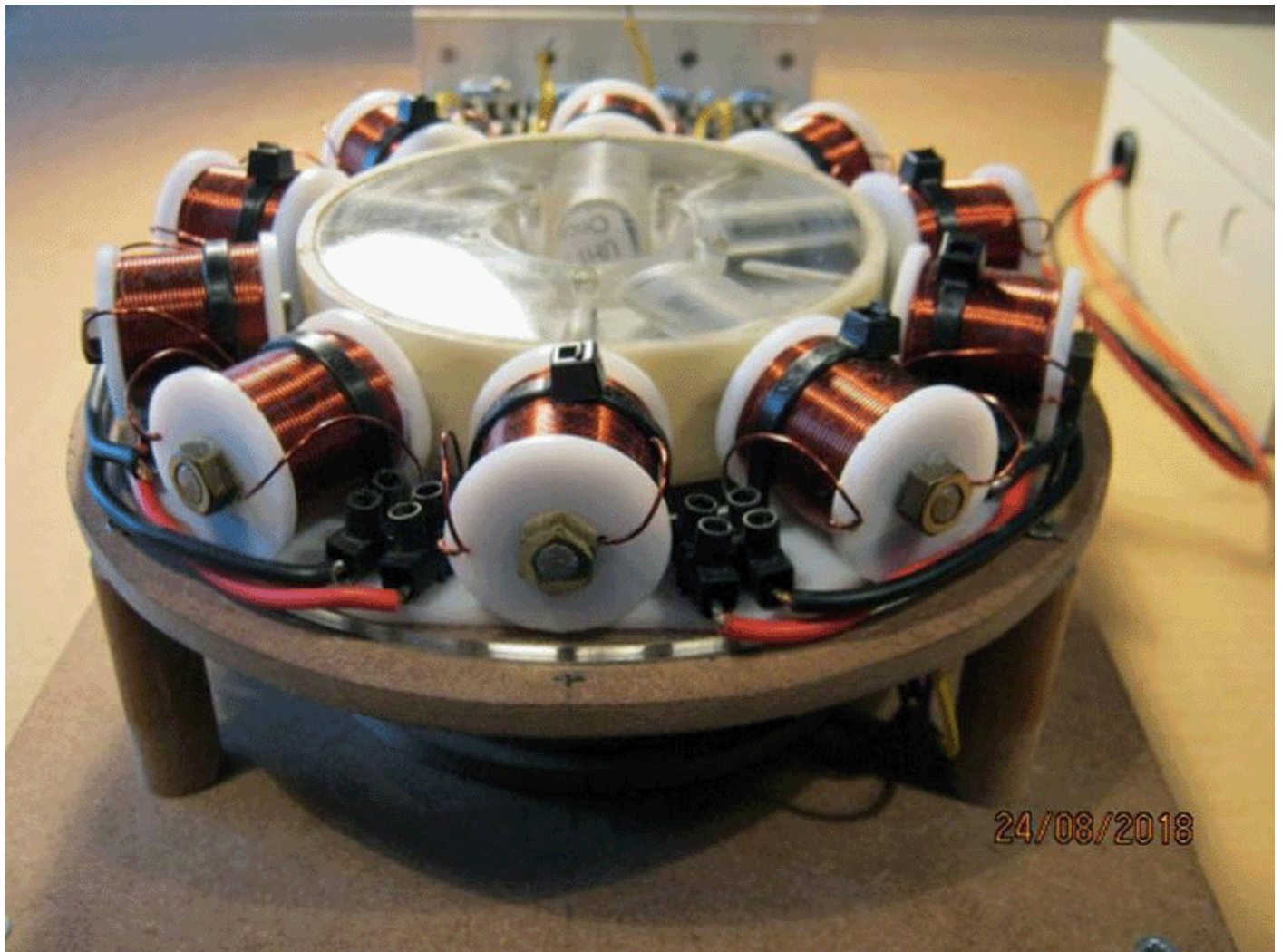

His designs are fine for people with good constructional skills and access to suitable equipment. However, it has always been desirable to have a motionless, solid-state version which generates excess power without moving parts or the constructor needing to have good skills and equipment.

This next step comes by applying common sense to the earlier designs which have proved to have very satisfactory operation and output. If the latest rotor version produces ten pulses per revolution and rotates at say, 2500 revolutions per minute, then the circuit generates about $2500 \times 10 / 60 = 417$ pulses per second. That is normally written as 417 Hz which is a low rate for an electronic circuit although it is a major rate of mechanical rotation

The circuit generates its excess power by applying these 417 pulses per second of 12-volts to two chains of five small coils in each chain. The circuit uses two separate Hall-effect sensors and it is like this:

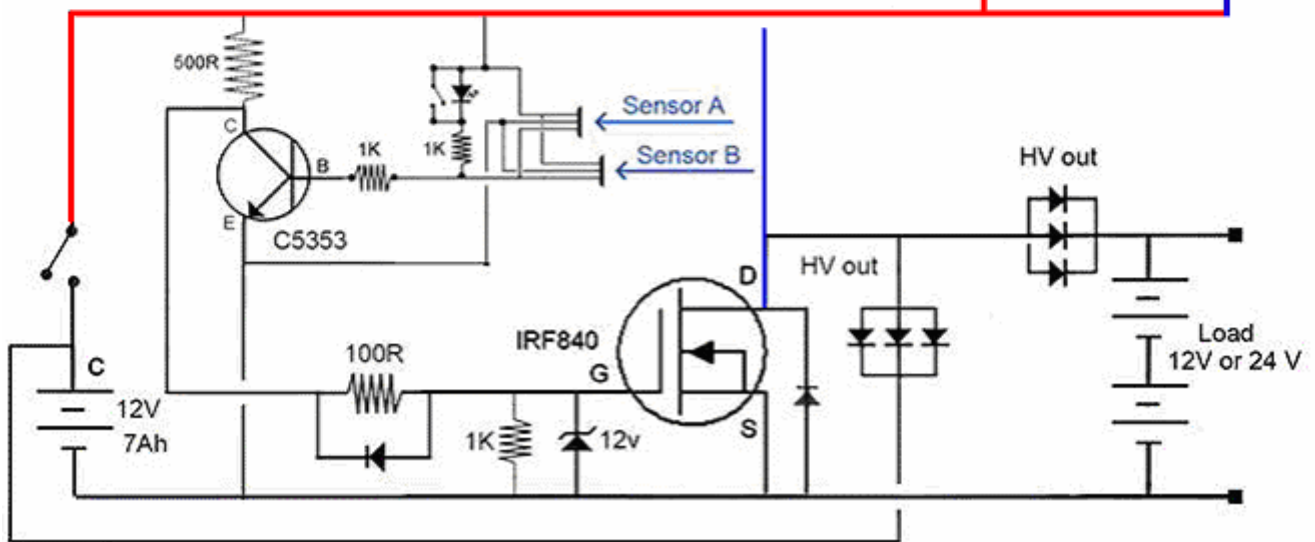
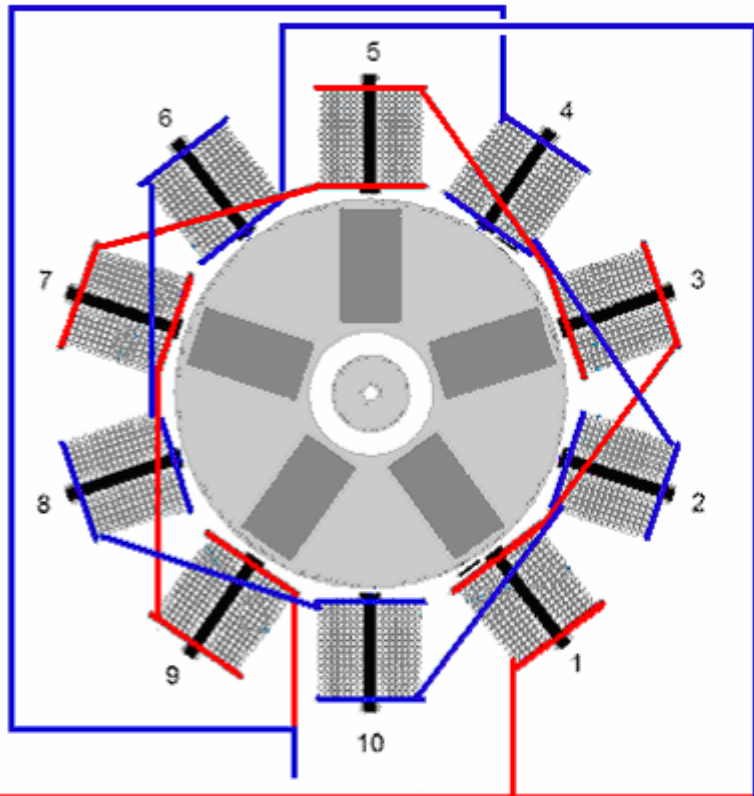

If we want to reproduce this performance without the rotor and its magnets, then we need to apply 12-volt pulses to those two chains of coils 417 times every second. That may sound difficult if you are not familiar with electronics, but in actual fact, it is a very simple task and 417 Hz is very slow operation for an electronic circuit as they could easily generate 3,000,000 pulses per second.

Because we live in an intense energy field, when each of those 12-volt pulses is cut off, the voltage across the coil chain rises very rapidly to more than 600-volts and that causes an inflow of energy into the circuit from our local environment. That inflow of energy is much greater than the original 12-volt pulse, and that is what we call "free energy".

The latest coils used with the rotor system are wound twelve layers deep and 27 mm long, on galvanised iron 6 mm diameter bolts. There is a common conception that iron can't change its direction of magnetism very fast. Personally, I'm not at all sure that that is actually correct, but initially, let us presume that we need to keep the pulsing down to say, 800 Hz or less. Of course, if we are winding coils for this solid state project, then we could wind them on a ferrite rod as the core as that should allow a much higher pulsing rate, and it is reasonable to presume that the greater the number of pulses per second, the greater the average excess output power will be.

Initial tests have been carried out using the existing ten coils which were used with the rotor circuit. The output proved to be satisfactory and pretty much equivalent to the rotor circuit output if the driving signal was 40% On and 60% Off:

Just initially, we will stay with low frequency (due to assumed iron core coil limitations) and run the testing using a circuit of this type:

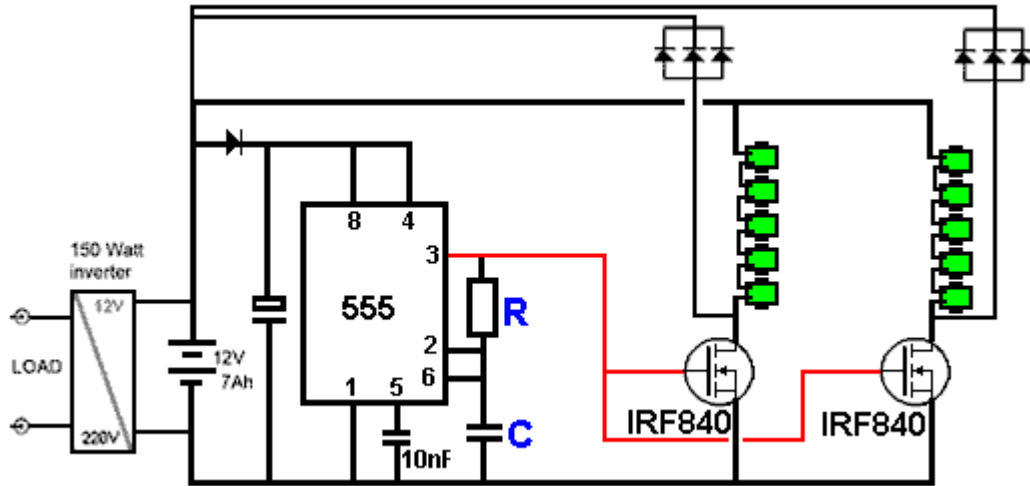

The resistor "R" and the capacitor "C" control the frequency of the pulsing and the result is very good. However, as the developer has powered both coil chains of his rotor circuit from a single transistor (although they generate at least 600V feedback pulses), he used just one transistor for his tests. He also likes to use his circuit which swaps over two drive batteries, one to provide current while the other one is recharging, but that is a minor matter.

So, let's say for argument sake, that the above circuit is running at about 500 Hz (C and R might be 100nF and 1.5K) in order to keep the coil frequency down, then there will be some 500 pulses per second returned to the drive battery. But, if we were to connect the circuit like this:

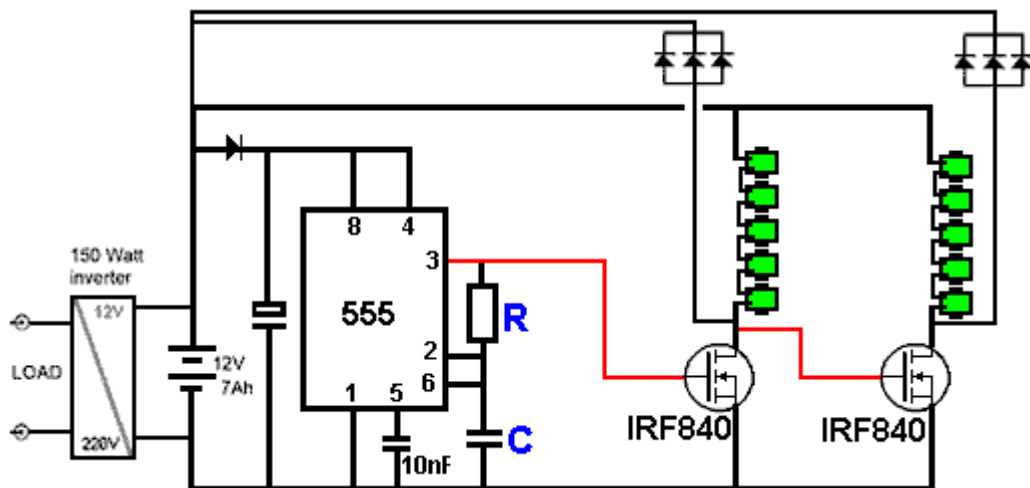

Then when the first transistor switches on, the second transistor switches off and vice versa. Doing that returns twice as many pulses per second to the drive battery without increasing the rate of pulsing of either of the coil chains. Remember also, that the transistors are powerful enough to drive several coil chains simultaneously, and each extra coil can be expected to increase the excess output power available.

However, testing shows that the output from the first transistor is not very good for switching the second transistor and so a better result is produced with the addition of a monostable circuit as that allows you to specify exactly what length of voltage pulse you want for the second transistor:

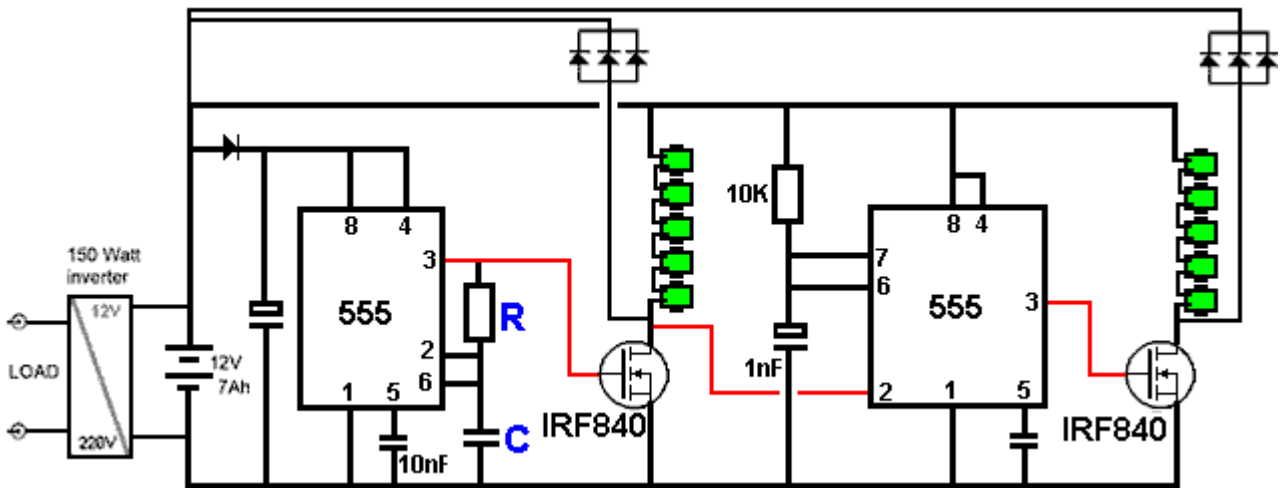

This technique of keeping the coils pulsed slowly while increasing the rate of pulses passed back to the output, can be extended further. It is perfectly possible to cascade ten or more coil chains during each of the 500 Hz pulses. That raises the output pulse rate without raising the coil pulse rate. This can be done by using a Divide-By-Ten chip, such as the CD4017B which can be wired to act as divide-by-9, divide-by-8, etc. down to divide-by-2. This is achieved by connecting the Reset pin (pin 15) to the next output. In the following circuit diagram, a divide-by-3 arrangement is shown and the divide-by-4 output is connected to the reset as that bounces the output back to output 1 again. The 555 clock is speeded up by a factor of three as it will take three times as long before the high voltage output of the 4017 chip returns to output 1 (on pin 3). The chip connections are like this:

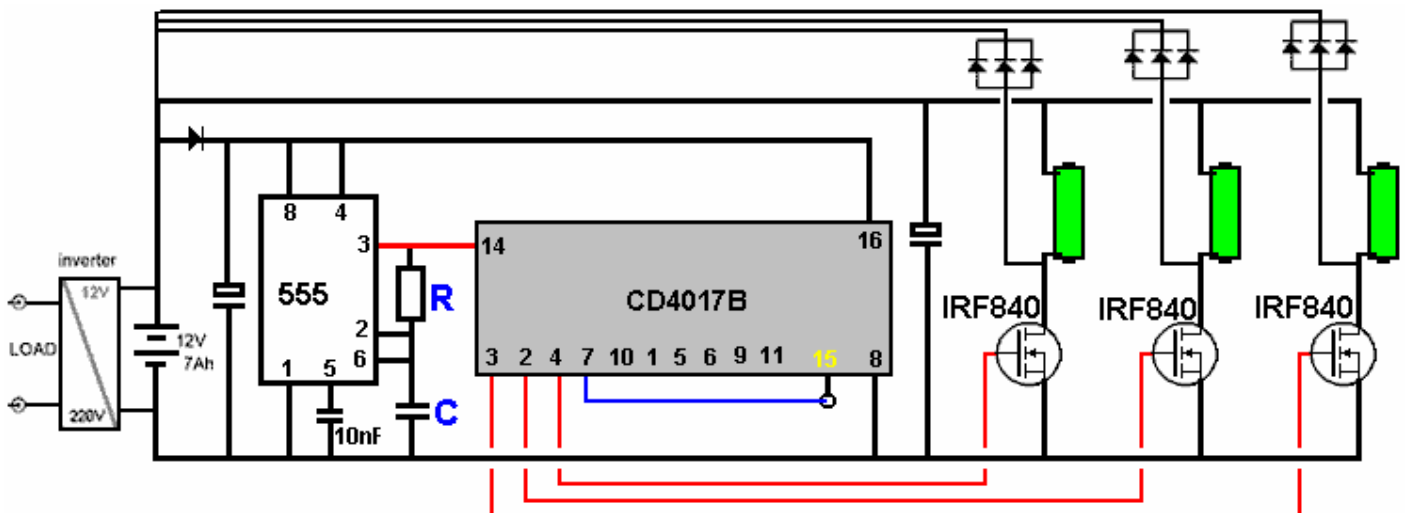
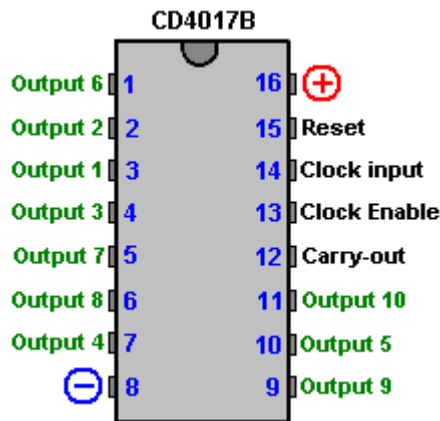

For a divide-by-4 output, pin 10 would be connected to Reset pin 15 and the fourth output would be from pin 7 and the 555 clock pulse rate increased to four times the original rate by lowering the value of “C” or increasing the value of “R”.

Please remember that the transistor needs to be able to handle high voltages if you decide to use a different type, also, you will need a more powerful DC/AC inverter to handle higher output power. There is essentially no limit to the output power you can achieve with solid state as you just add more coils and possibly more transistors. Please use a heat sink with each transistor.

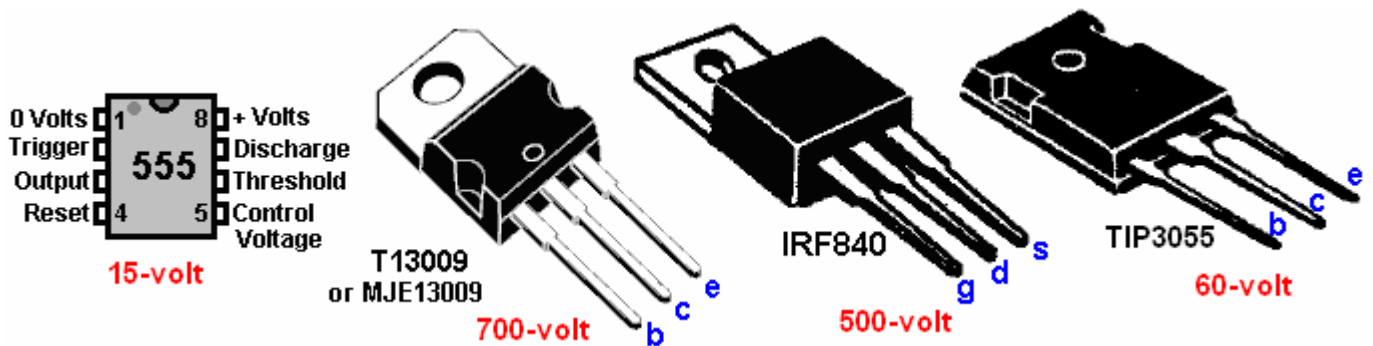

If you decide to use a 24-volt input, please remember that both the 555 chip and the 4017 chip need to be kept down to 12-volts as they are not able to handle 24-volts. Also, you need a 24-volt inverter if you decide to do that.

If experimentation shows that your particular construction of the circuit works better at higher and higher frequency of clock pulses, and that results in each coil driving transistor needing a longer drive voltage period than the length of one divide-by-N clock period, then that can be dealt with by using a monostable on each output as shown by the shaded portions of this diagram:

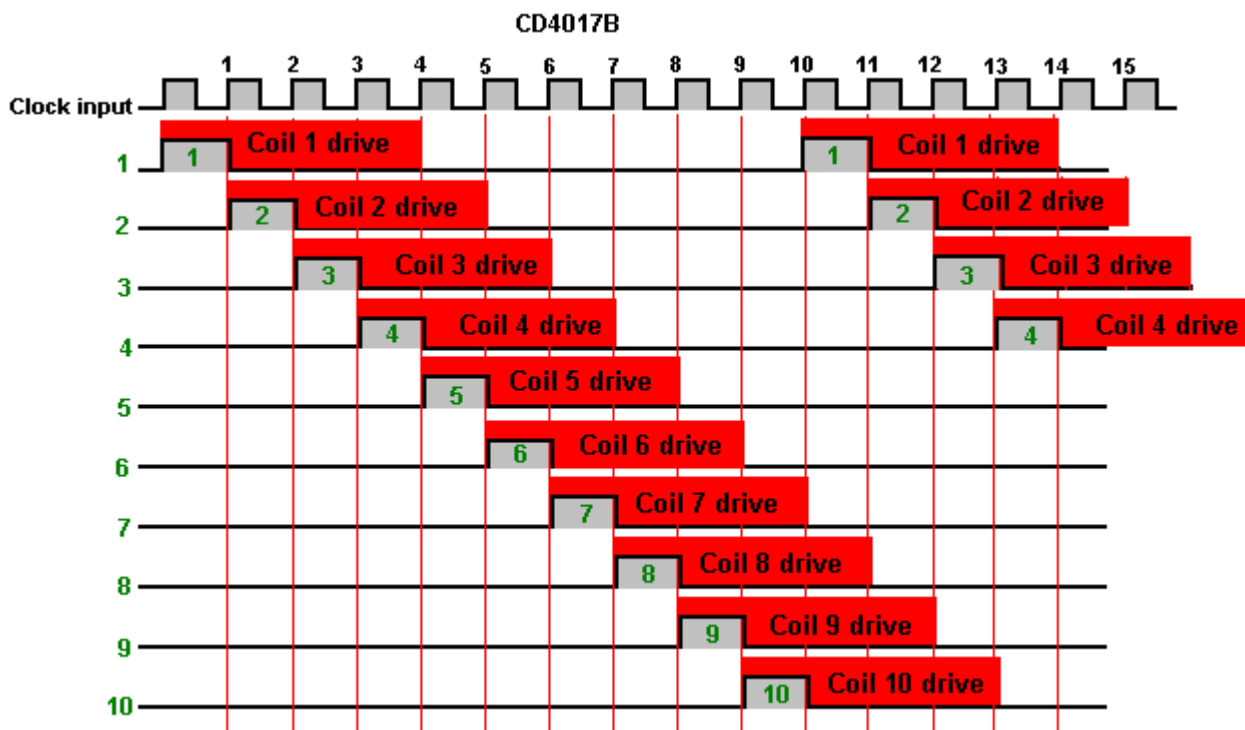

Now that there is no need to construct a precision rotor with magnets, the only significant task is to wind the coils which generate the excess power. It is perfectly possible to wind perfect coils without any equipment at all. First, you need to choose the wire diameter and buy in the wire needed. Wire of 0.71 mm diameter is popular (swg 22 or AWG 21) and is easy to work with. Then you need to choose the core material – iron (not steel) or ferrite and create a spool with that core by attaching stiff flange discs of about 30 mm diameter at the ends of the core for iron. The coils shown here are wound on 8 mm iron bolts with windings 75 mm

long, eight layers of wire and 40 mm diameter flanges (which could be much smaller):



Three of these coils can be wound from a single 500 gram reel of 0.71 mm wire and the iron cores can certainly operate at more than 6000 Hz. Each of these coils has about 315 turns and a DC resistance of 1.6 ohms. However, ferrite is generally considered to be a better core for high frequency operation and these can be wound quite easily. Using the same 0.71 mm diameter wire (swg 22 or AWG #21), a 140 mm long ferrite rod of 10 mm diameter can be wound quite easily without any equipment, and six coils with three layers each can be wound from a single 500 gram reel of wire, and each coil has about 590 turns and a DC resistance of one ohm.

The basic ferrite rod has a 20 mm diameter disc of stiff cardboard glued to each end. It looks like this:



Cut a 140 mm wide piece of paper 32 mm long. This width matches the gap between the spool flanges. Attach a strip of Selotape to the paper so that it overlaps by half its width all along the paper strip and set it aside until the first layer of wire has been wound.

You can hang the full spool of wire on a rod hung from the edge of a table or desk. Push the first few inches of wire through a hole through the flange near the core and start winding by turning the spool in your hand. The winding needs to be done carefully so that the turns lie cleanly side by side with no gaps between them and no turns overlapping any other turn:

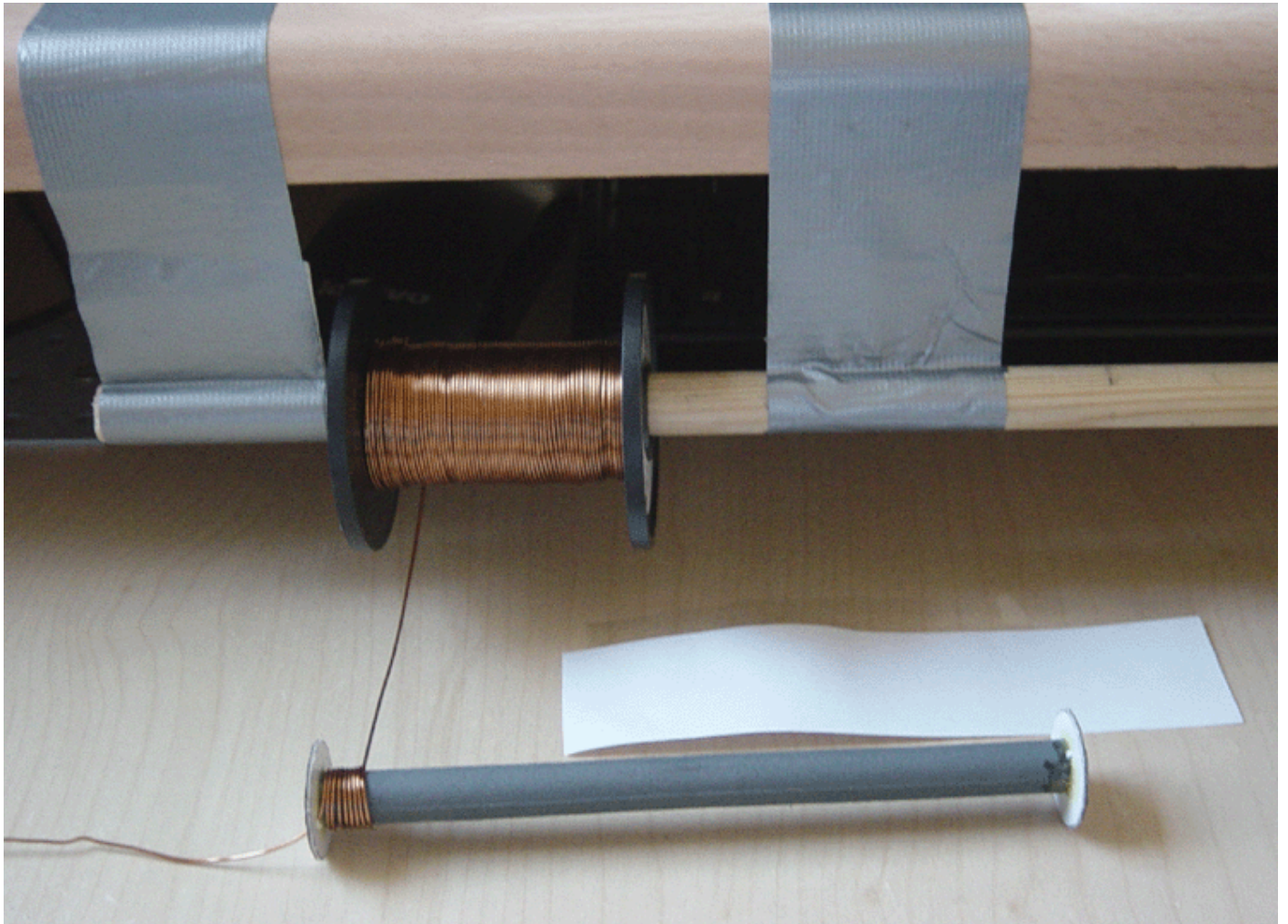

When the far end of the spool is reached, stick the piece of paper to the layer of turns using the Selotape already on the paper, bend the paper round the layer of winds and pull it tight using other strips of Selotape to hold it in place as you move progressively along the length of the spool. The paper will not be long enough to go all the way around the layer as the core now has the wire thickness making the core larger, but that is quite intentional as you don't want more than a single layer of paper. You will need the paper layer to allow you to see the next layer of wire clearly as you wind it. If you don't have that paper layer it is enormously difficult to see the next layer well enough to detect winding errors as the wire is exactly the same colour as the first layer.



You now have a perfectly wound first layer. Before starting the second layer, cut the next strip of paper, measuring 40 mm wide. Stick a strip of Selotape along the length of the paper, again, with half of the width of the Selotape overlapping the paper and set it aside. Wind the next layer in exactly the same way, finishing by sticking and securing the paper around the core with its two layers of wire.

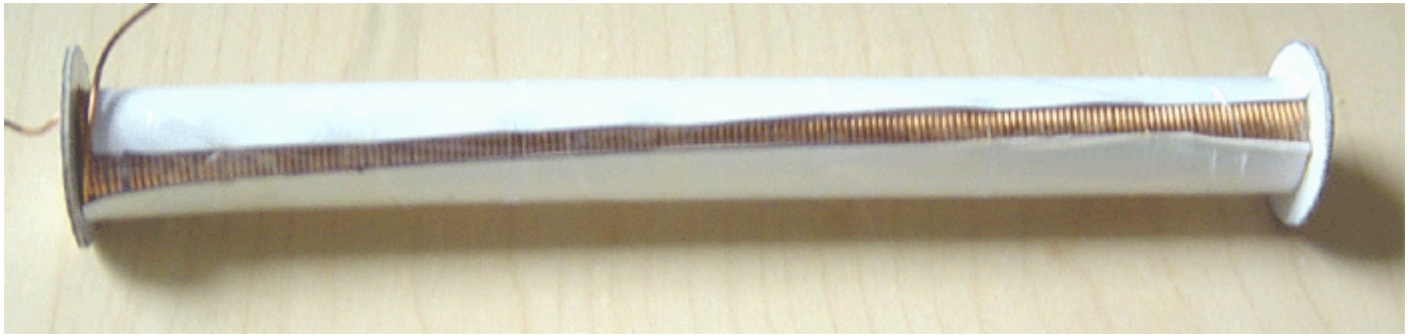

That process is repeated until all of the desired layers have been wound. Finally, the wire is cut with a few inches left for connecting the coil in the circuit, and the wire is passed through a second hole in one of the flanges:

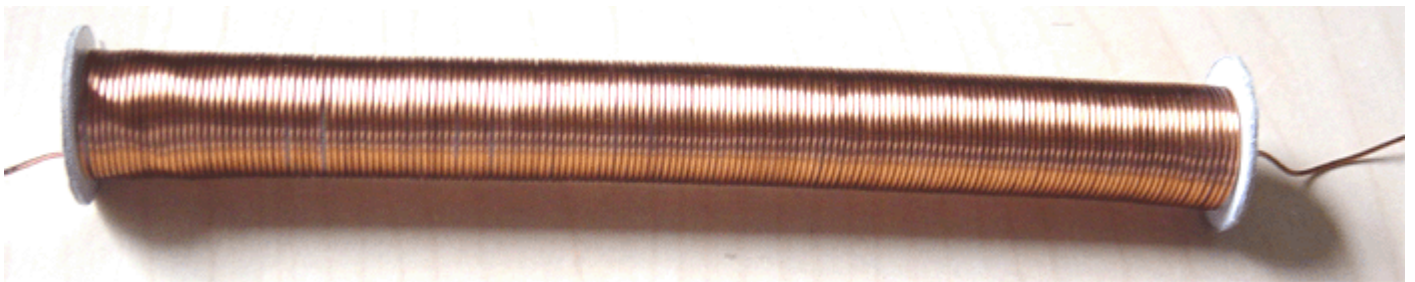

This generator can be built in thousands of variations, the main difference being the coils being used – the core material, the core length, the wire diameter, and the number of layers wound. You can, of course, start with one coil and see how your circuit performs, and later on, add one or more coils to boost the performance.

The way that coils perform is not at all obvious. It is generally agreed that the larger the number of turns, the greater the voltage produced when the coil is pulsed. BUT, other factors are also important. The impedance of the coil (it's AC resistance) makes a very big difference when the coil is being pulsed. That is affected by the core material, the wire diameter, the wire material, the number of turns, the quality of the winding, how spread out the turns are, the number of layers, etc. Generally speaking, it is probably best to wind a series of coils and test them to see which works best for you, and then wind the remaining coils to match your best result.

If you wish to use two separate drive batteries, one to power the circuit while the other is recharging, then that is perfectly possible. Batteries which are providing power to a load don't charge nearly as well as unloaded batteries being charged. However, the mechanism which switches between the two sets of batteries needs to have extremely low current draw in order not to waste current. One possibility for that would be to use a latching relay like this:

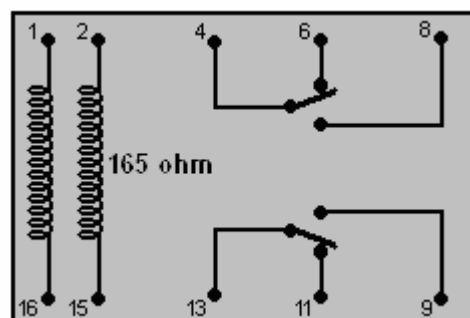

This is the electronic version of a mechanical two-pole switch. A brief pulse of current between pins 1 and 16 locks the switch in one position and later, a pulse of current between pins 2 and 15 locks it in the other position. The current drain on the circuit would be almost zero.

While standard NE555 integrated circuits can operate with a supply voltage down to 4.5 volts (and in practice, most will operate well at much lower supply voltages), there are several much more expensive 555 ICs which are designed to work at much lower supply voltages. One of these is the TLC555 which has a supply voltage range from just 2 volts right up to 15 volts, which is a very impressive range. Another version is ILC555N with a voltage range of 2 to 18 volts. Combining one of those chips with a latching relay produces a very simple circuit as the 555 timer circuit is exceptionally simple:

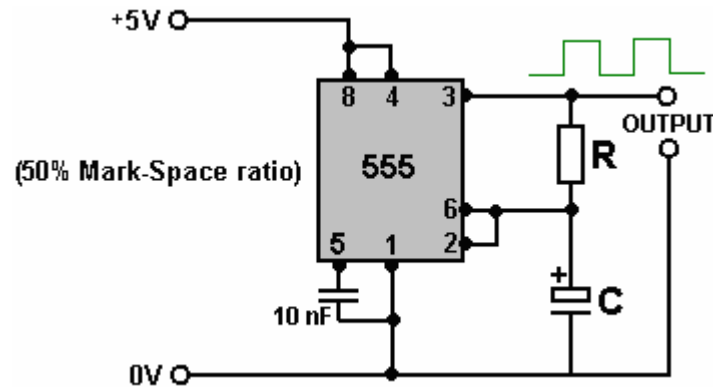

The capacitor used has to be high quality with very low leakage in order to get this waveform which is On for exactly the same length of time as it is Off. This is important if we want the two batteries to receive the same length of time powering the load as the time they receive being recharged.

A weakness of the 555 chip timer from our point of view is that it has only one output while we need two outputs, one falling when the other rises. That can be arranged by adding a transistor and a couple of resistors like this:

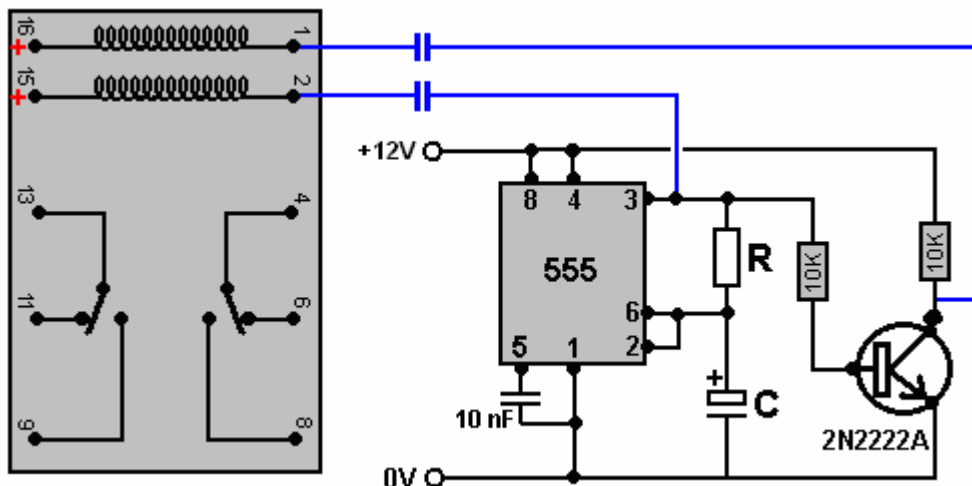

With this circuit, when pin 3 of the 555 chip goes low, the capacitor connecting it to pin 2 of the relay pulls that pin 2 voltage low and causes the relay to change state as the relay pin 15 is connected to +12V, causing a current surge through the coil as the capacitor charges. A few moments later, when the capacitor has charged up, the current drops away to zero. Five minutes later pin 3 goes high again and that switches the transistor on causing its collector voltage to drop rapidly to near zero. That pulls pin 1 of the relay down low causing it to change state before the capacitor has a chance to charge up.

This is fine if the capacitors shown in blue are poor quality and their charge bleeds away in a period of five minutes. Nowadays, even cheap capacitors are generally much too good quality to allow that to happen and so we need to connect a resistor across the capacitor to create that drop in charge. But that additional resistor is connected continuously and so it needs to be of a high enough value not to waste any significant

current – perhaps 18K would be a reasonable choice. An 18K resistor with twelve volts across it draws only 0.667 of a milliamp of current.

So, if we prefer, we could use this circuit, perhaps laid out like this:

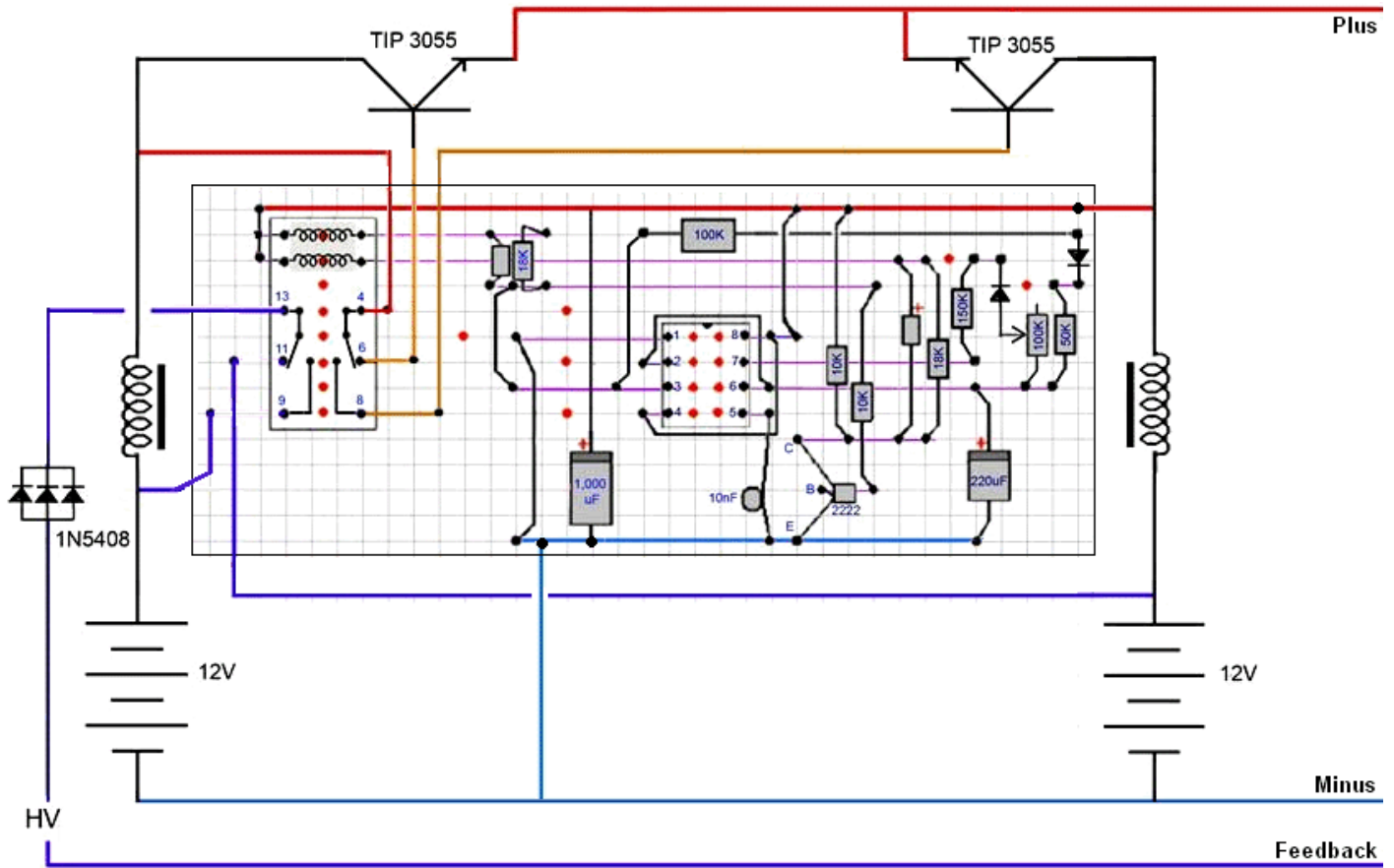

The TIP3055 transistors are there only to raise the current carrying capacity of the tiny latching relay. Let's decide to build a very simple version of the circuit but allowing for later expansion for greater output power. Let's try this circuit arrangement:

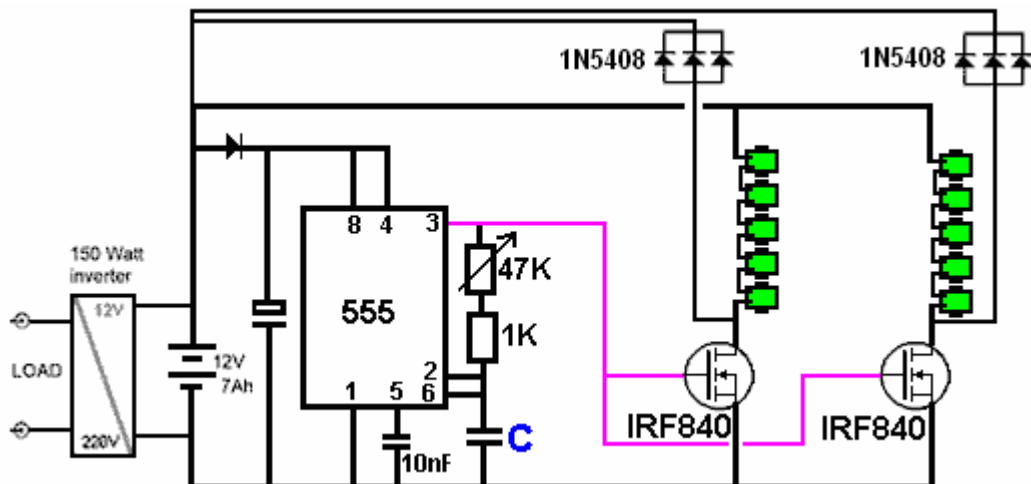

This arrangement allows for considerable alteration of the operating frequency by merely turning a knob. Experienced constructors will have their own preferred methods of construction, but we might choose to use a layout on an open board in order to make it easy to see what is happening and to give good cooling during the development stage, perhaps something like this:

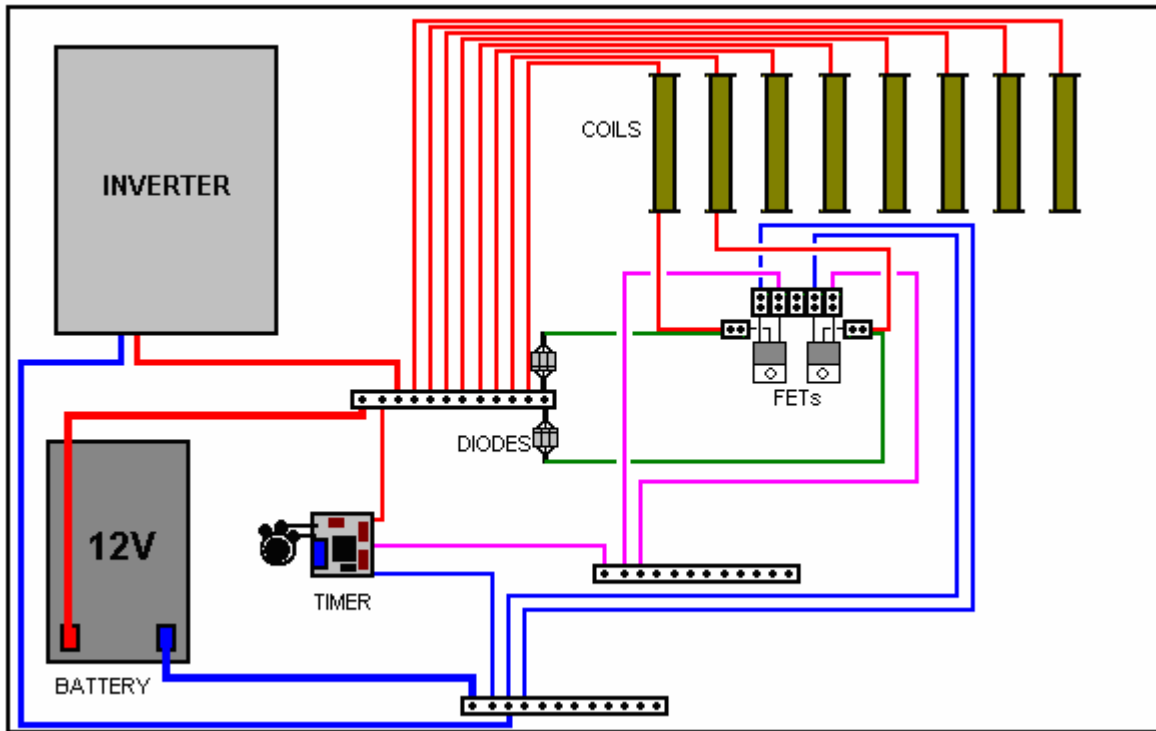

This arrangement keeps soldering to a minimum and allows for easy alterations as the circuit is extended for higher output power. The timer board can be swapped out later on if you decide to use a Divide-by-N style of operation.

Two types of screw connectors are used. One type has all of the connectors connected so that many wires can be connected to a single point. They look like this:

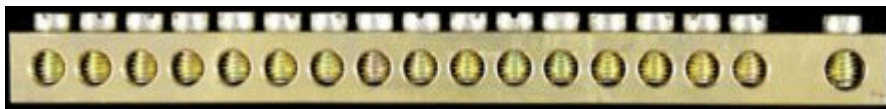

Unfortunately, these connectors cost about £5 each which is several times more expensive than the standard connector which has each connector insulated from all of the other connectors in the block:



If cost is a major factor, then a standard connector strip can be converted to a single multiple output strip by wiring one side with a thick piece of wire like this:

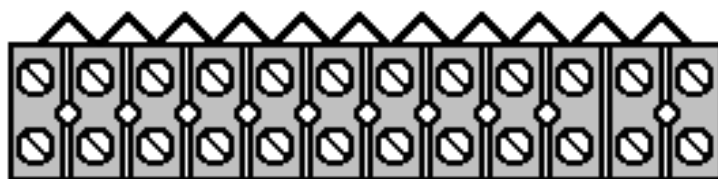

We have a problem with connecting the FET transistors because their pins are so close together that they don't fit conveniently into a screw connector block. We can get around that problem by cutting one connector off the block, bending the central pin of the FET upwards into a vertical position and using the single cut off connector to make the

connection to the central pin of the FET:



The layout of the timer is not at all critical and a layout like this might be used:

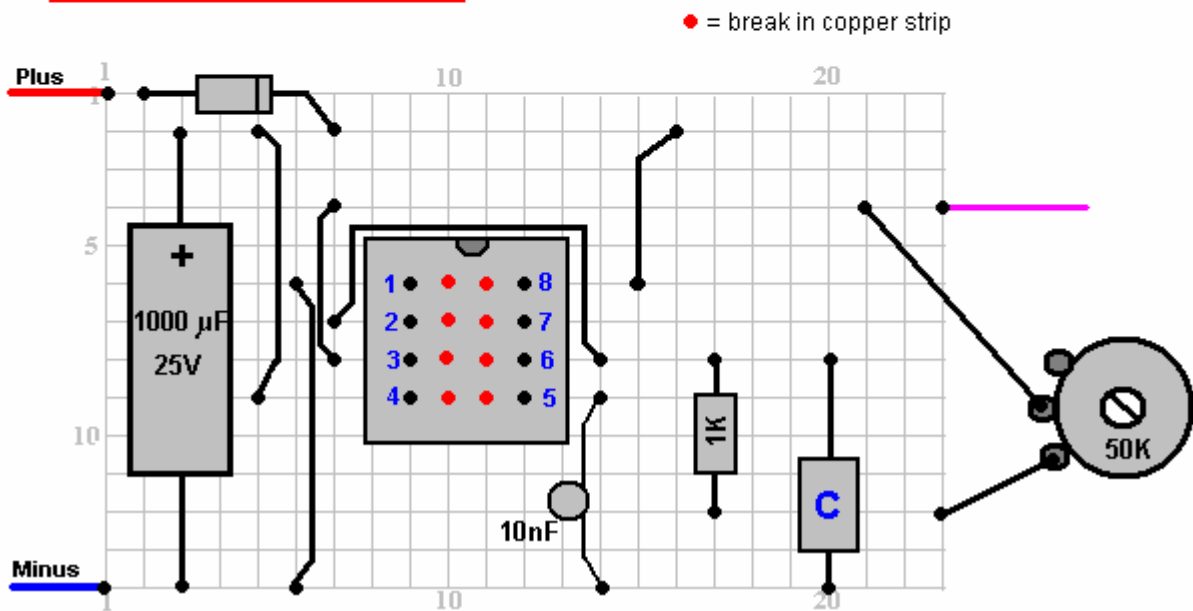
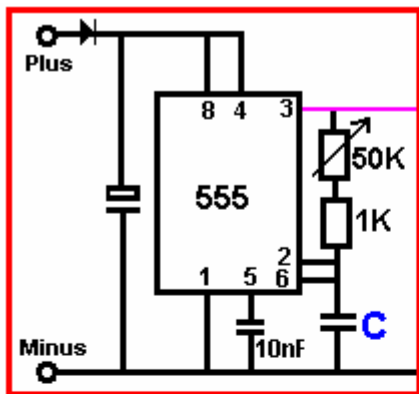

The capacitor "C" will be about 10 nF and the variable resistor can be 47K or 50K linear or a higher value could be used.

So, if you were going to build this generator, how might you go about it? Well, you might start by building the timer board shown here, either as shown or to your own layout. I strongly recommend using a socket for the 555 timer chip as transistors, Integrated Circuits and diodes can easily be damaged by heat if they are not soldered quickly. As the generator is for your own use, you can avoid the horrible lead-free solder which is so difficult to work with and I suggest that 0.8 mm diameter multicore solder is the right size for this work. So, to construct the timer board you will need:

1. A soldering iron of about 40 watts, and 0.8 mm cored solder.
2. Stripboard ("Veroboard") with 14 strips each with 23 holes.
3. A drill bit or a knife to break the copper strips which run between the pins of the 555 chip.
4. One 8-pin Dual-In-Line socket for the 555 chip.
5. Some solid-core plastic covered wire to form the jumpers on the board.

6. The components: One 555 chip, one 8-pin socket, one 1000 microfarad 25V capacitor, two 10 nanofarad ceramic capacitors, one 1K resistor, one 50K or 47K or higher linear variable resistor, one diode which could be 1N4007, or 1N4148, or almost any other diode.
7. A magnifying glass of some description. A cheap plastic one can be quite sufficient. This helps greatly when examining the underside of the board to make sure that solder joints are well made and that there is no solder bridging between adjacent copper strips.
8. A cheap digital multimeter for measuring voltages and resistance.

Not essential but very, very convenient is one of those angled arm clamping devices which are usually supplied with a magnifying glass. If you discard the magnifying glass, the angled arms can hold the board and component in place, leaving both hands free to do the soldering. A cloth wet with cold water is very good for cooling down soldered joints rapidly to prevent heat damage.



Start by breaking the copper strip in columns 10 and 11 on rows 6 to 9. This is needed in order to prevent the strips short-circuiting the pins of the 555 chip. Mount and solder the 555 socket in place (if you bend the legs outwards along their strips it holds the socket in place and makes for a good solder joint). Then, cut solid core insulated copper wire to the correct lengths and solder the five wire jumpers on the board:

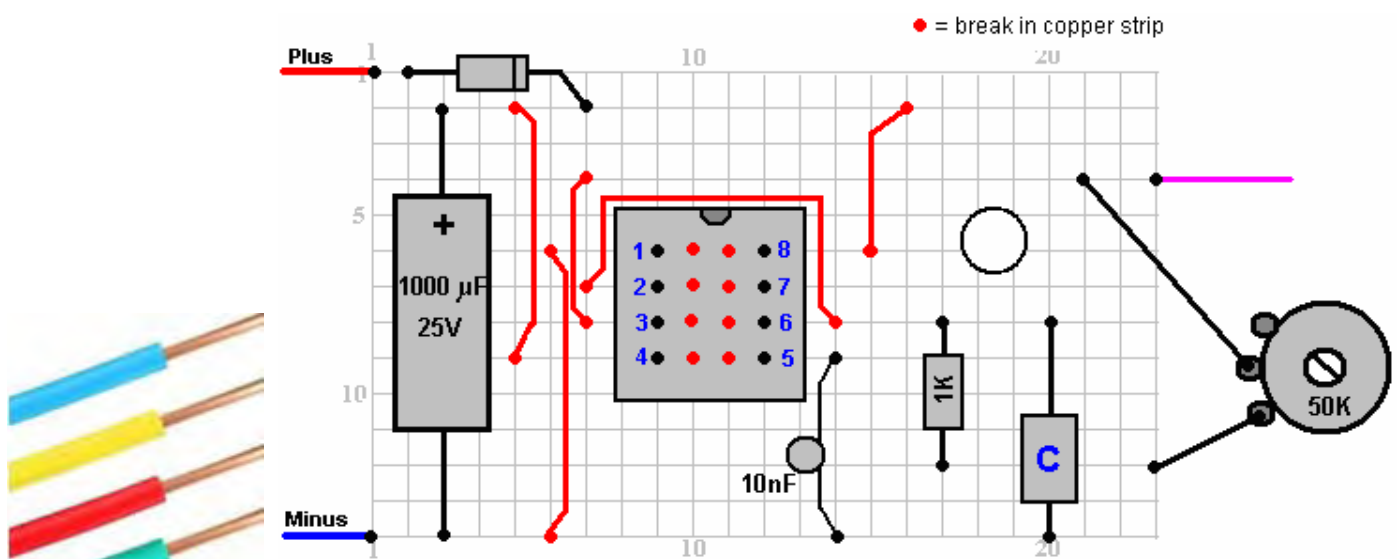

Then work from left to right, mounting the remaining components. The capacitor "C" has got a lot of spare space around it so that it can be altered at a later date if you decide that you should.

Finally, connect the variable resistor (which many people mistakenly call a “pot”) and the positive and negative connecting wires using multi-strand copper wire as that is much more flexible, and lastly, the connecting wire from pin 3 out to the distribution block which connects to the FET gates. Check that the circuit has been connected correctly and that there are no soldering errors on the underside of the board – this is much easier with a magnifying glass as the gaps are very small.

Set the variable resistor shaft to about its mid position, connect the board to a 12-volt source of power and measure the voltage coming from pin 3 of the 555 chip. The voltage should be about half of the supply voltage and should not change much when you adjust the variable resistor.

We are now ready to start assembling the generator, getting a suitable board and attaching to it the inverter and the battery:



These two units can be attached to the base board by drilling holes through the board and using string or wire to bind them securely in place.

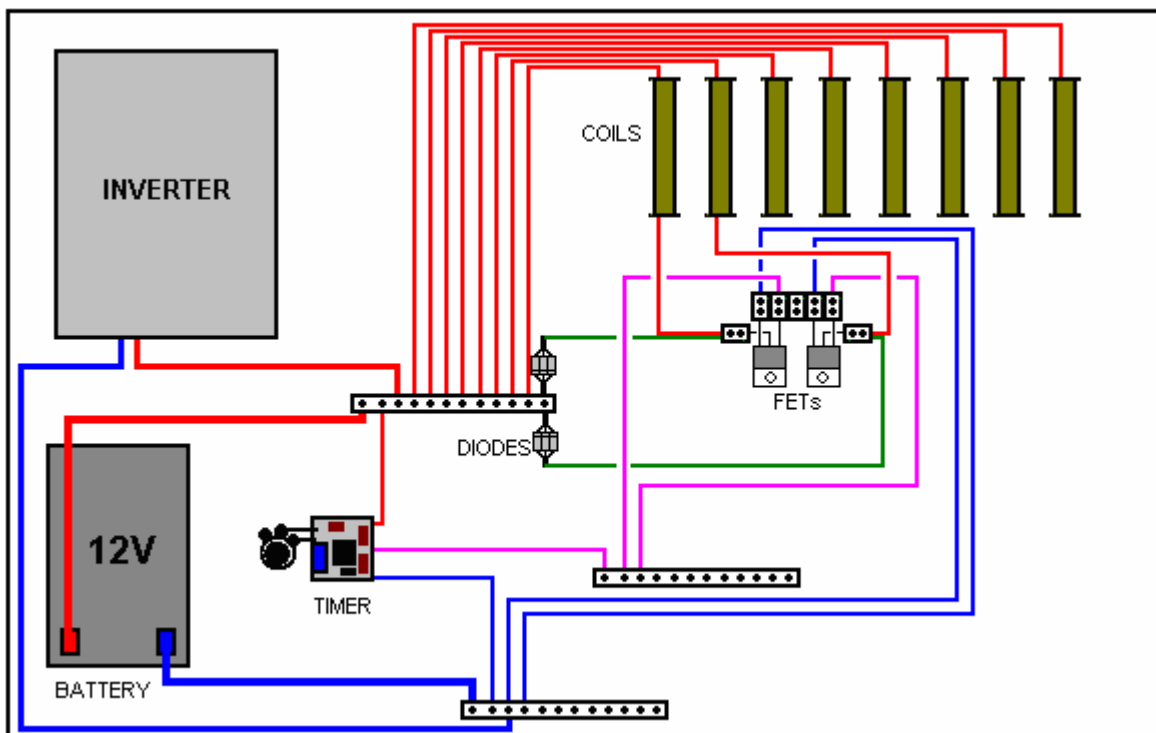

The timer board can be attached to the base board using a screw or a bolt. The board is very light and robust and a single screw is quite sufficient to hold it neatly in place. The variable resistor and the three connecting strips can be glued to the board. Some constructors hate the idea but my preferred method is to use Impact Evostick as the glue as it is very effective and after a day or so becomes very strong indeed.



The diodes used are 1N5408 types and although each one can handle 3 amps of current, they are grouped in sets of three as that lowers the very slight resistance to current flow through them as well as raising the possible current to nine amps.

My inclination is to use a separate FET with each coil, but the South African developer states that he can detect no difference between driving two coils with one FET and driving those same two coils with two separate FETs.

Please understand that this presentation is for information purposes only and it is not an encouragement for you or anyone else to actually build one. Also, no representations are made that this design will produce any particular level of output power.

If you wish to use two batteries with the switching circuit, then the layout on the base board might be like this:

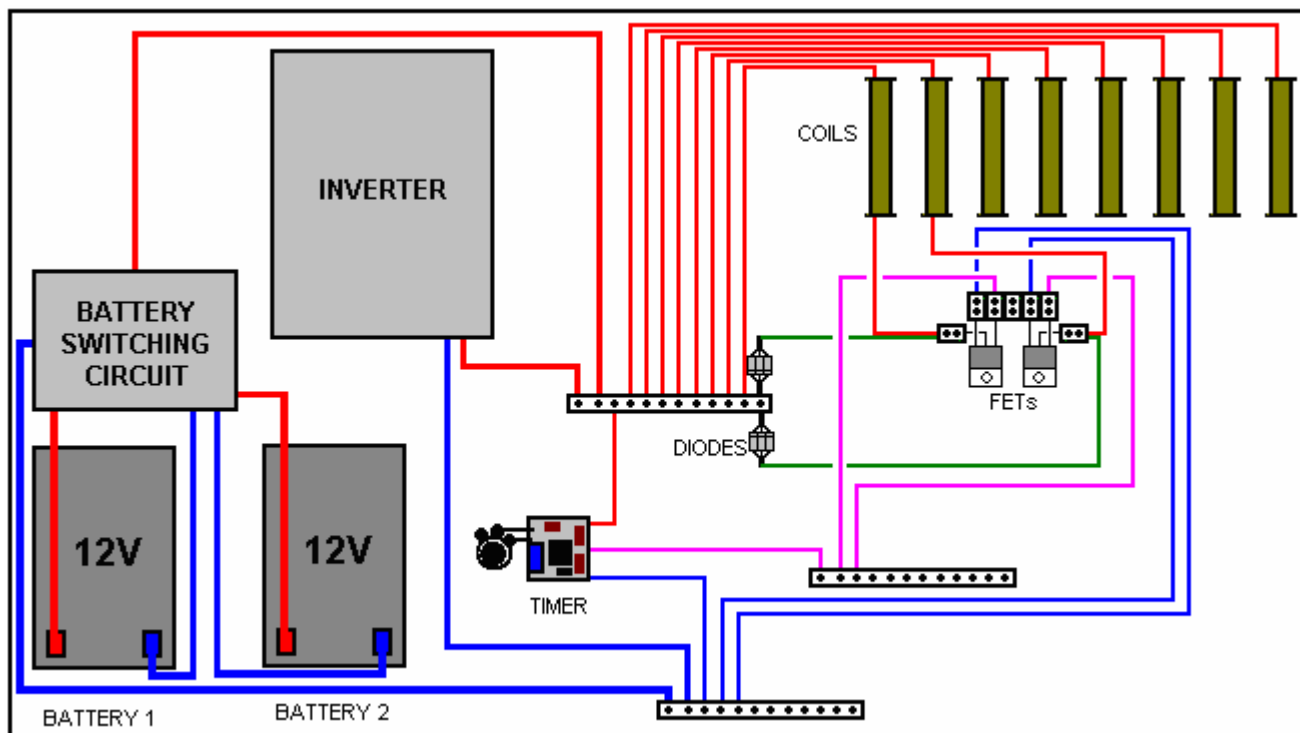

What look like coils on the battery swapper circuit are actually chokes and they are just a few turns of wire on an iron or ferrite core.

Patrick Kelly
www.free-energy-info.com
www.free-energy-info.tuks.nl