



JULY 2017

Battery energy storage systems

The power to control energy

ABB Power Quality Products

Battery energy storage systems

Definition

Combination of:

- an energy storage device (battery)
- a power converter (ESI)
- a controller which facilitates the charge and discharge of the battery based on certain algorithm

The energy is stored in the battery bank or retrieved from it to achieve certain tasks

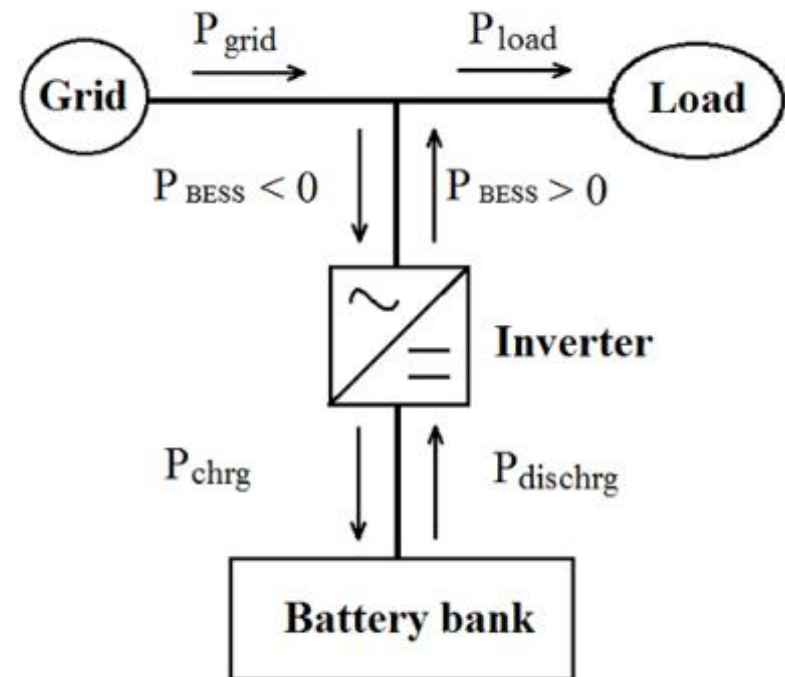

Battery energy storage systems

Definition

Application of energy storage system:

- Short terms (seconds) or long term (hours) depending on the battery discharge duration
- Based on installed power or stored energy

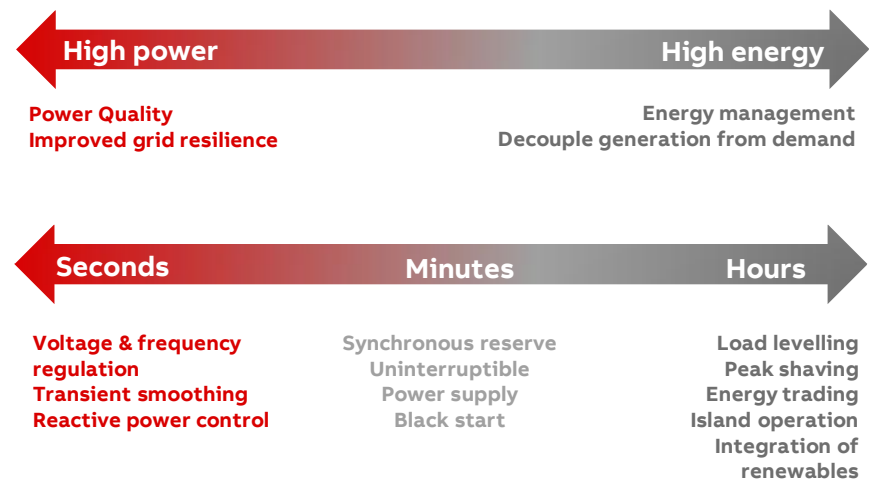

Battery energy storage systems

Application

Peak shaving (demand charge reduction)

- Reduction of demand during peak hours when the cost of electricity is high in order to reduce the energy cost (demand side)
- From the supply side, the goal is to avoid the installation of capacity to supply the peaks of a highly variable load.
- Peak shaving installations are often owned by the electricity consumer, rather than by the utility

Energy storage provides fast response and emission-free operation, making it the optimal solution for such application.

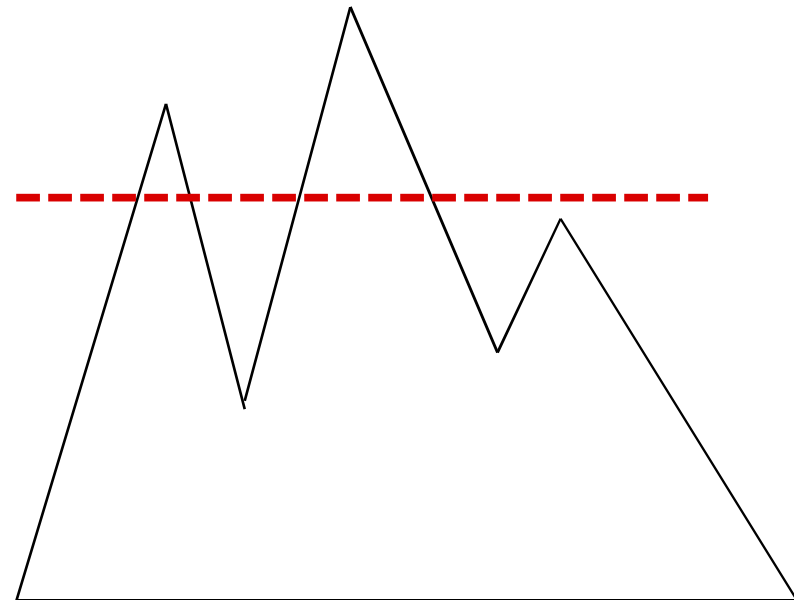

Battery energy storage systems

Application

Peak shaving - benefits

- Commercial and industrial customers save on their electricity bills by reducing peak demand
- Utilities reduce the operational cost of generating power during peak periods (reducing the need for peaking units)
- Investment in infrastructure is delayed due to the flatter loads with smaller peaks

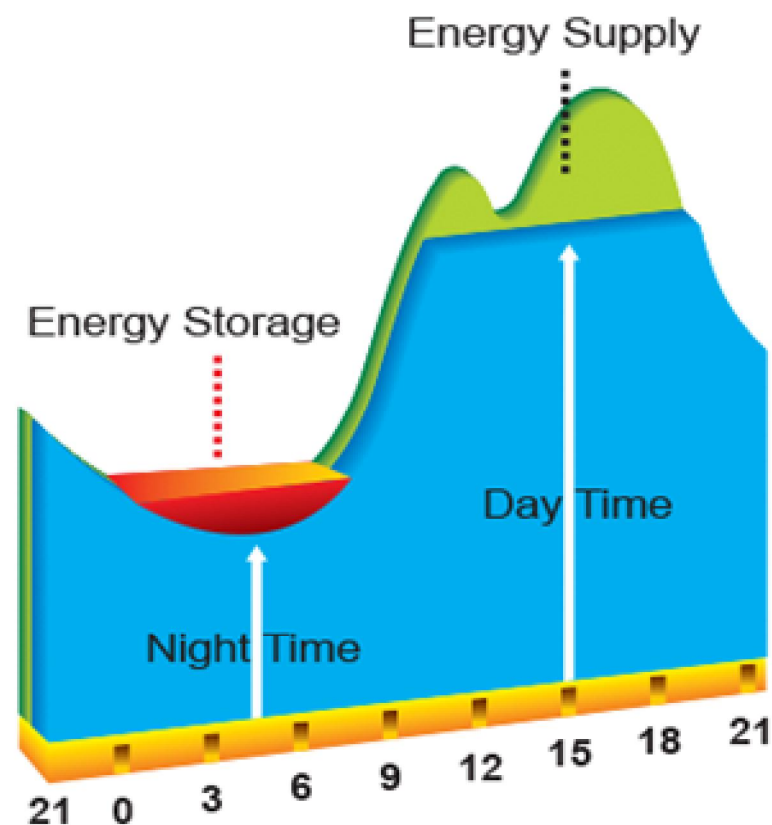

Battery energy storage systems

Application

Capacity firming

- The variable, intermittent power output from a renewable power generation plant, such as wind or solar, can be maintained at a committed level for a period of time.
- The energy storage system smoothes the output and controls the ramp rate (MW/min) to eliminate rapid voltage and power swings on the electrical grid.

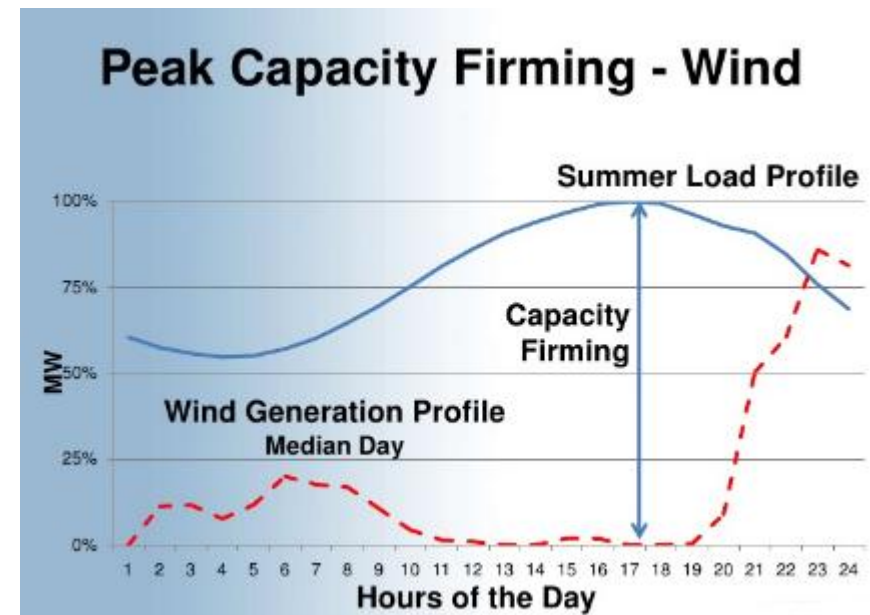

Battery energy storage systems

Application

Capacity firming - benefits

- Renewable operators: compliance to the grid codes
- Utilities: less “unbalance” in supply and demand of electrical power
- Improvement of overall reliability of the system

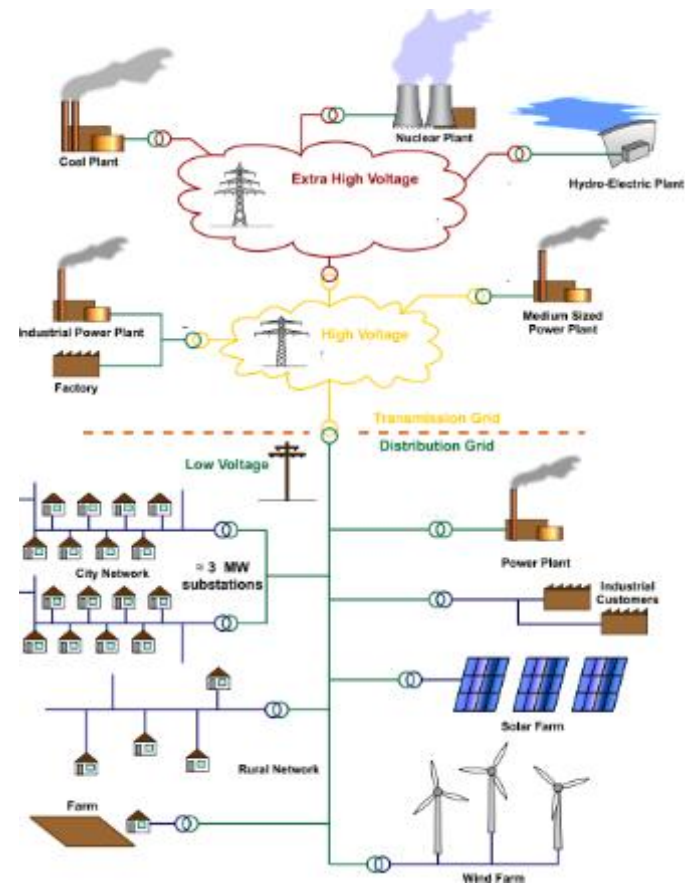

Battery energy storage systems

Application

Frequency response

- Unbalance in demand (load) and supply (generation) of electricity leads to change in network frequency
- If not corrected in time, change in frequency may lead to unacceptable situations
- Several protections and countermeasures are built in the system

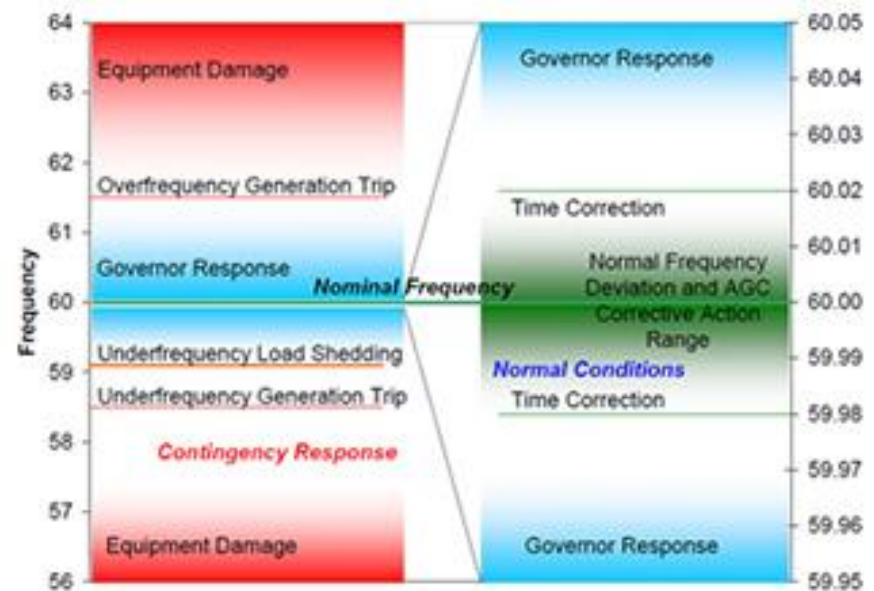

Battery energy storage systems

Application

Frequency response

- The energy storage system is used to act fast for durations from short to long duration
- React to the change in network frequency
- Release “burst” of energy in to the grid when the frequency is below the nominal level
- Absorb “burst” of energy from the grid when the frequency is above the nominal level

Energy storage provides fast response (in less than a second) making it ideal solution for such application.

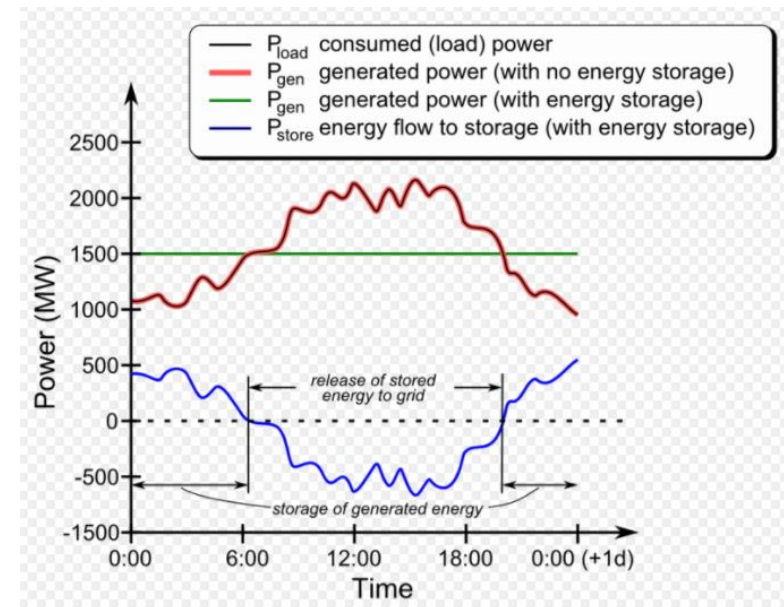

Battery energy storage systems

Application

Frequency response

- Primary frequency response lasting up to 30s
- Secondary response up to 30 min

Energy storage provides a good solution for both primary and secondary responses

Benefits:

- Utility: Maintains network frequency within acceptable limits, more stable operation of the grid
- End user: More reliable power supply

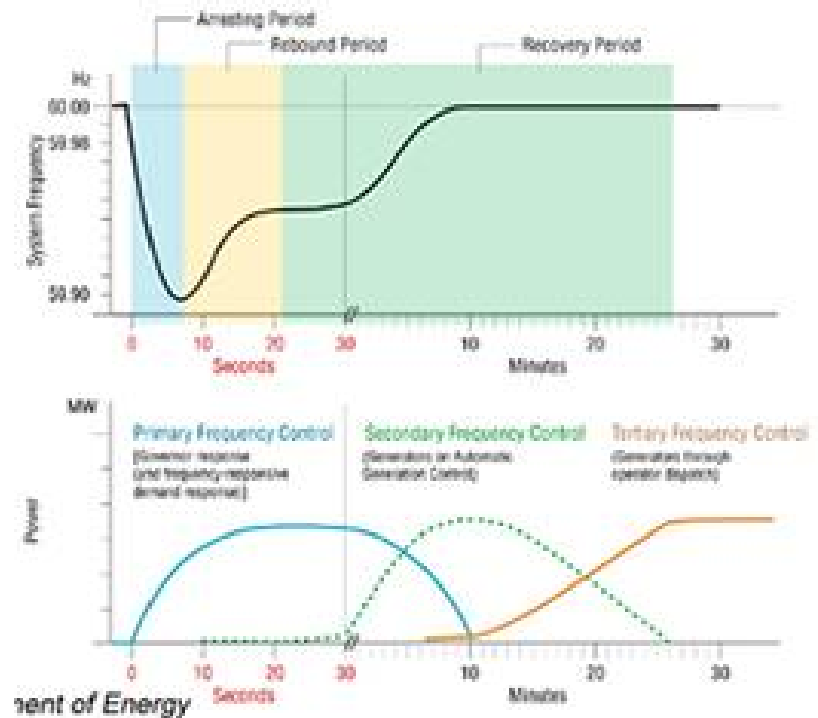

Battery energy storage systems

Application

Power quality

Power quality related to the load mainly means

- Harmonic filtering
- Load balancing
- PF correction (reactive power compensation)

Energy storage system can provide the much needed power quality functionalities without stressing the battery. These features are basically built in the inverters.

Benefits:

- Utility: Lower losses in the network, improved overall efficiency of operation
- End user: Adherence to international norms, improved operational efficiency, avoidance of penalty, lower losses, extended lifetime for equipment,.....

Battery energy storage systems

Applications

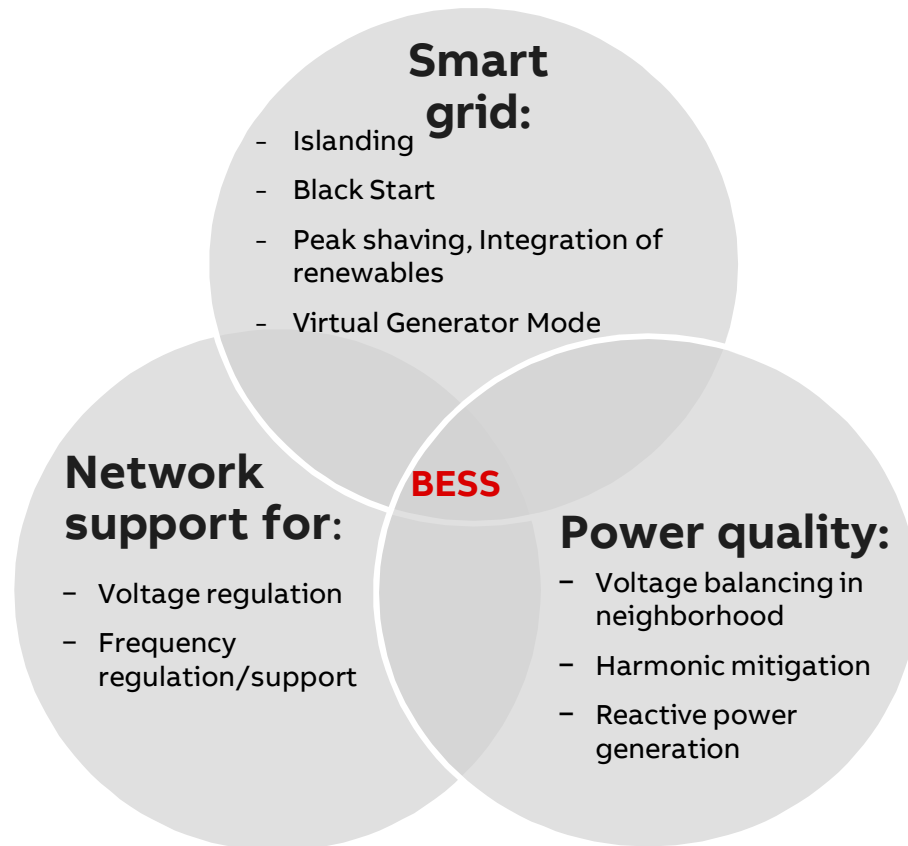

Power range:

- 20kW à 2.5MW

Multi communication capability:

- CAN
- Modbus TCP/RTU

Flexible and modular design

Battery energy storage systems

User implementation

Applications	Users			
	Industrial, commercial and residential	Renewable integrators	Transmission and distribution operators	Power stations
Peak shaving	✓			
Load leveling	✓	✓	✓	✓
Frequency regulation		✓	✓	✓
Ramp rate control/ Capacity firming		✓		
Power quality	✓	✓	✓	
Spinning reserves			✓	✓

Battery energy storage systems

Product portfolio

Complete system

- Power conversion system (PCS)
- Energy storage batteries
- Higher level controller (EMS) based on PLC or equivalent

Optional items:

- MV transformer, switchgear
- Technical services (FAT, SAT.....)

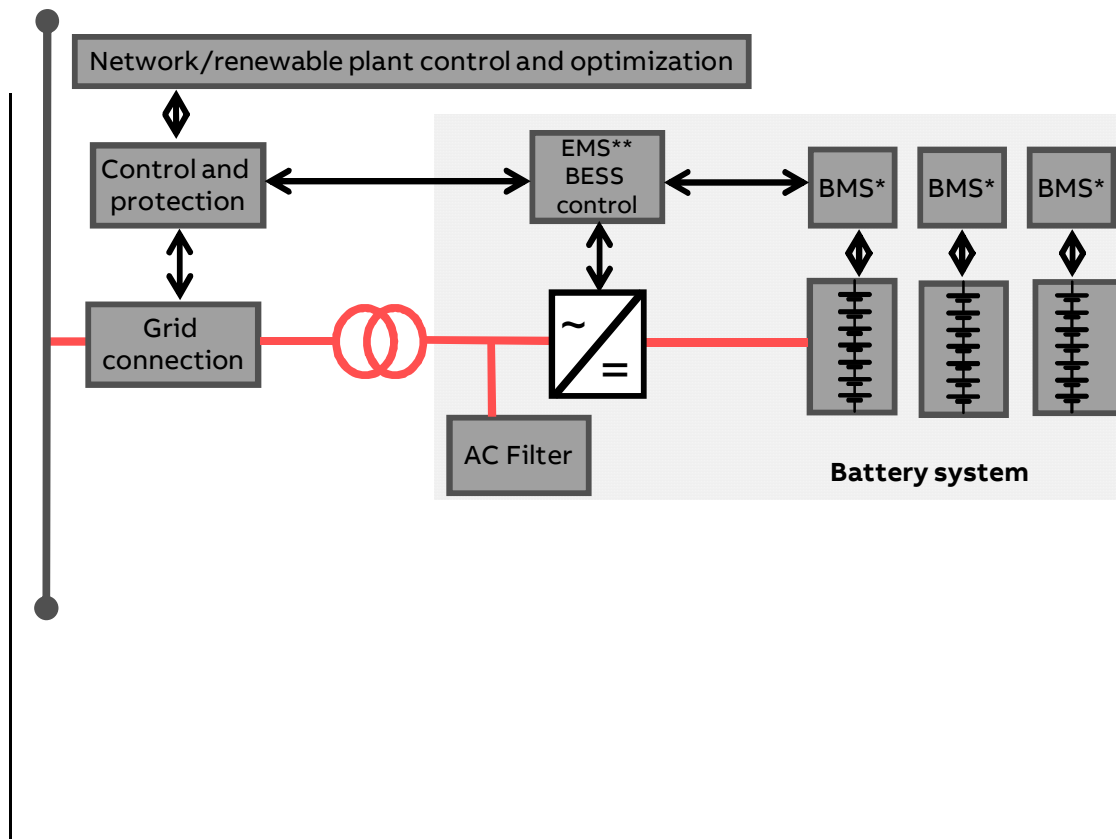

Battery energy storage systems

Product portfolio

Different topologies available

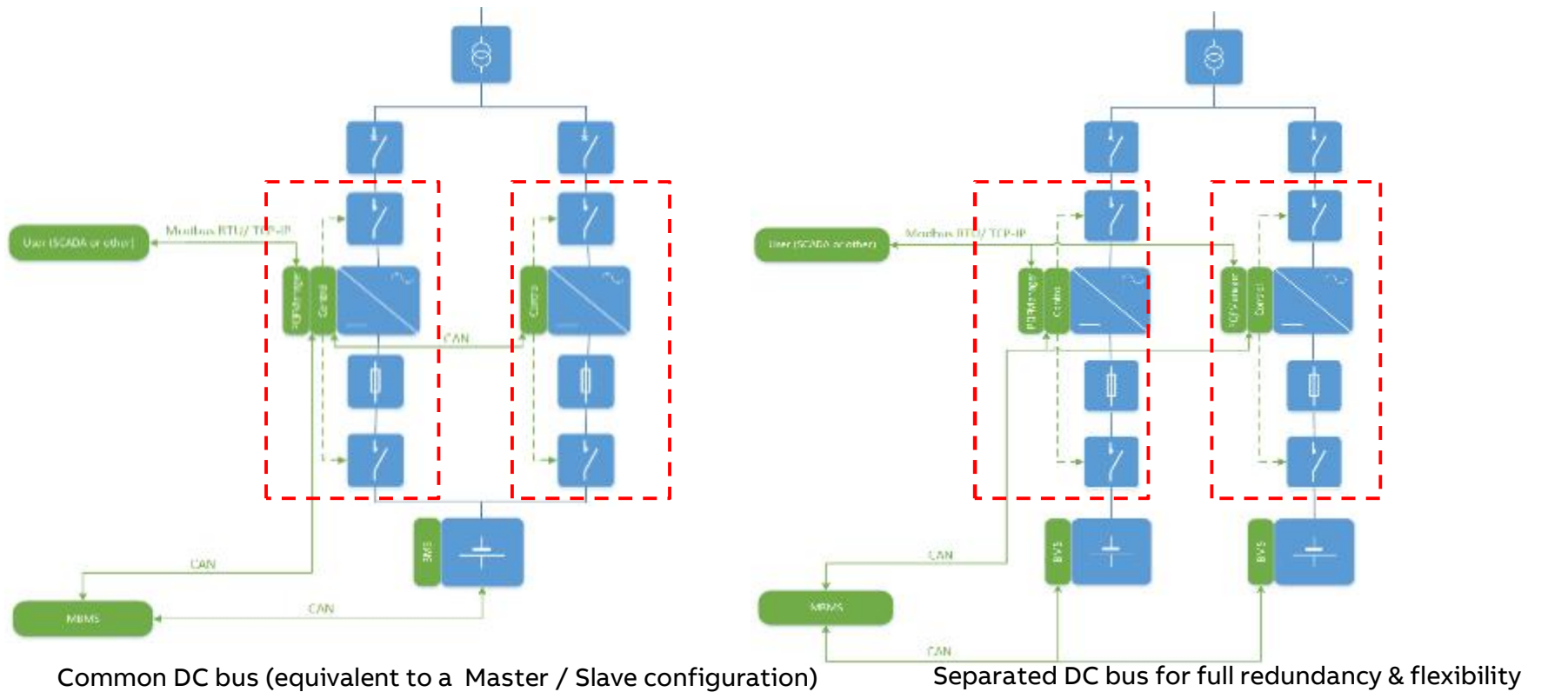

Battery energy storage systems

Product portfolio

Power conversation system (PCS)

- Different inverters for different applications and powers
- ABB's own design and production
- Wide power range
- Loaded with Power Quality functionalities(ESI)
- 3-Ph 3-Wire & 3-Ph 4-Wire capabilities(ESI)
- Possibility of 1-Ph inverters(ESI)

Battery energy storage systems

ESI Product portfolio

Energy storage inverters range

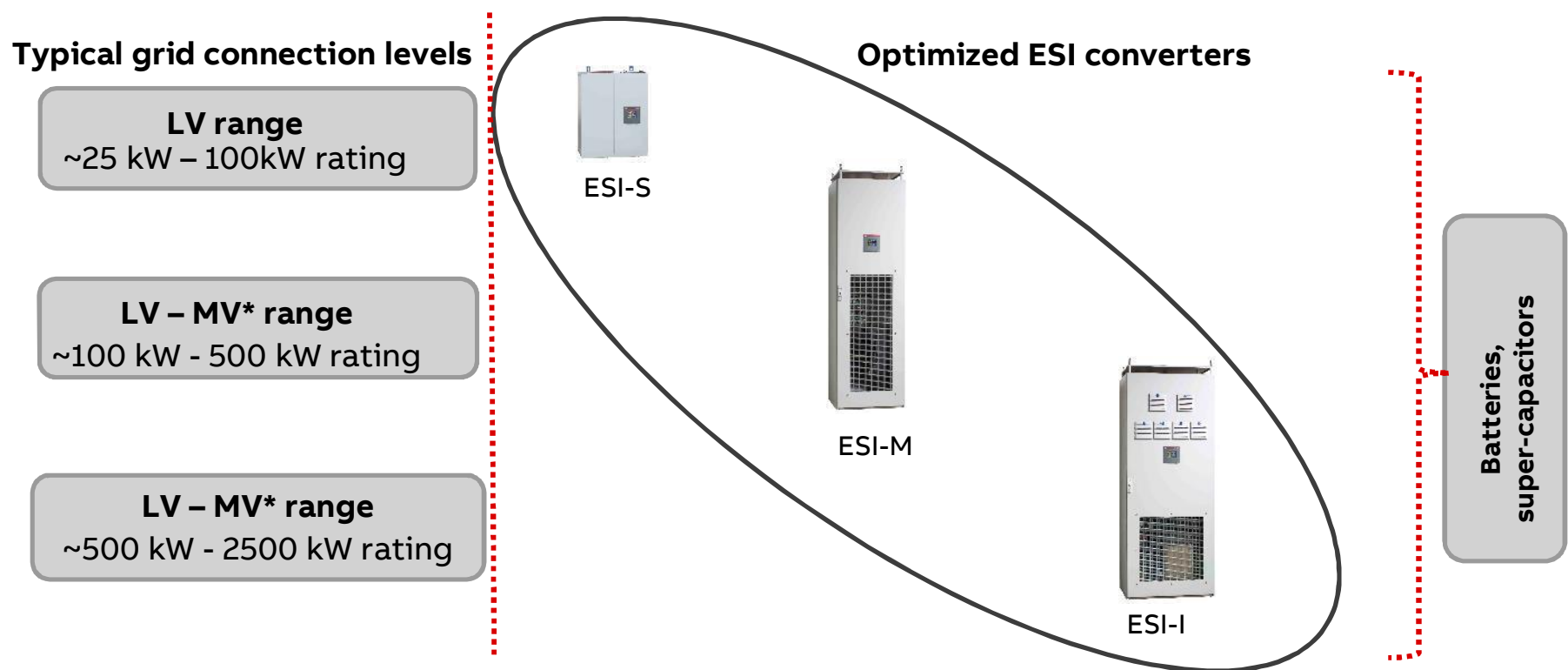

Battery energy storage systems

Product portfolio

Energy storage device (battery)

- Li-Ion batteries:
 - First choice as high energy density, high charge-discharge cycles
 - Other type of batteries can be offered
- Selection of right batteries depending on specific application
- 585Vdc – 1200Vdc (other DC voltages possible)
- System tested with world class batteries (LG, Samsung, Saft, Electrovaya, Nilar,...)
- Experienced team of engineers for application engineering



Battery energy storage systems

Product portfolio

Energy Management System (EMS)

- ABB's programmable logic controller (PLC) as high level controller
- Functionalities offered such as peak shaving, load shifting, frequency regulation, capacity firming, ramp rate control etc.
- System compatible with any other EMS (preferably communicating in Modbus protocol)



Battery energy storage systems

Product portfolio

Small systems

- Inverter
- Battery
- EMS (optional)
- Documentation
- Optional services
 - Factory acceptance test (only on PCS)
 - Site acceptance test (SAT)
 - Commissioning assistance
- Usually suitable for indoor installation
- Power range: 10s of kW to few 100s kW

Battery energy storage systems

Product portfolio

Medium systems

- Inverters
- Batteries
- Higher level controller (EMS)
- Documentation
- Optional services:
 - FAT
 - SAT
 - Commissioning assistance
- Medium systems are suitable for indoor as well outdoor (in container) installation
- In case of containerized solution, cooling control and fire fighting system is also offered
- Range: few 100s kW to 1000s kW

Battery energy storage systems

Product portfolio

Medium systems – Typical scope

- Inverter, battery and the EMS
- Cabling between the components (power & communication)
- System design
- Factory acceptance and Site acceptance test
- Documentation

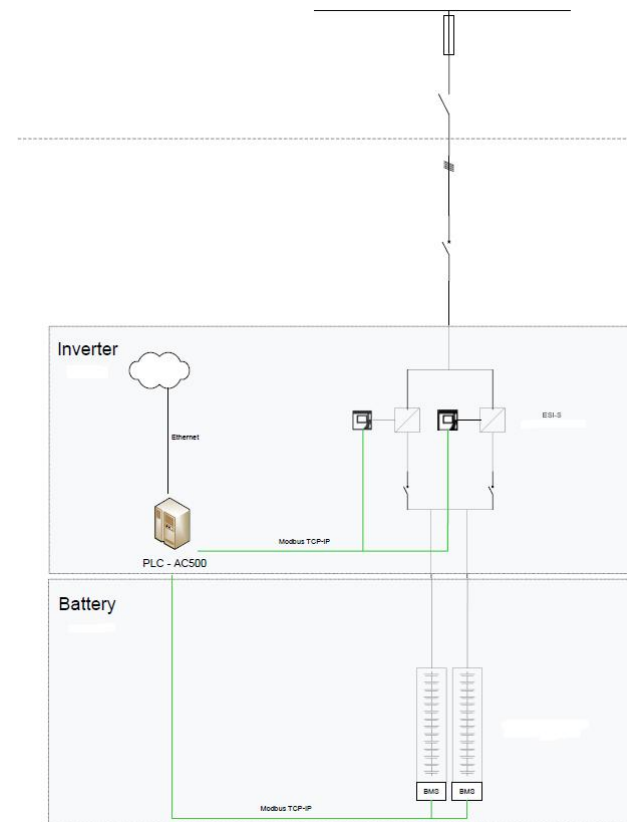

Battery energy storage systems

Product portfolio

Medium systems – Typical layout (indoor)

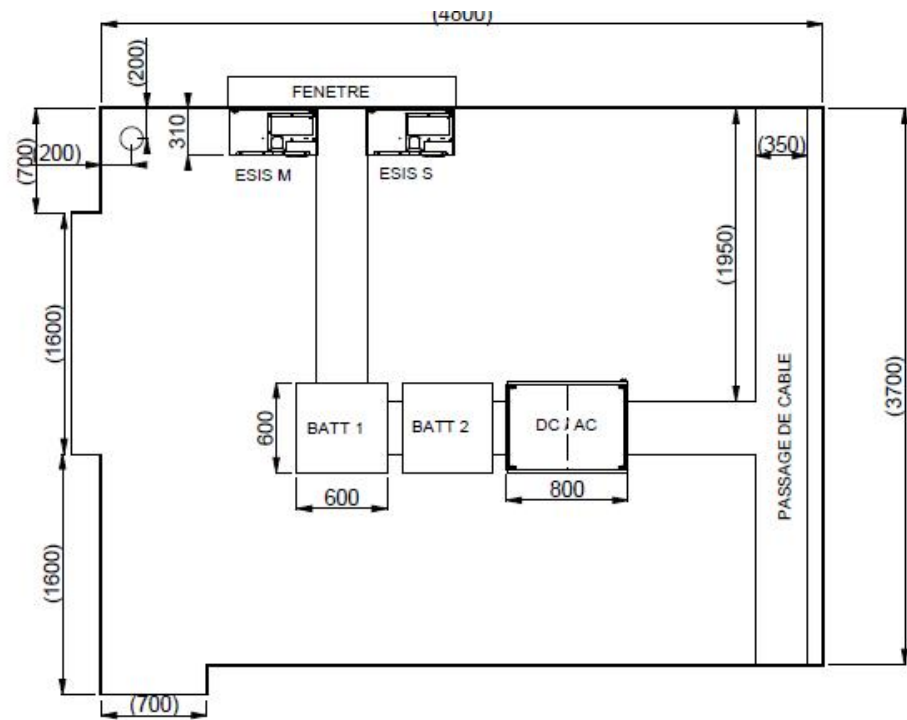
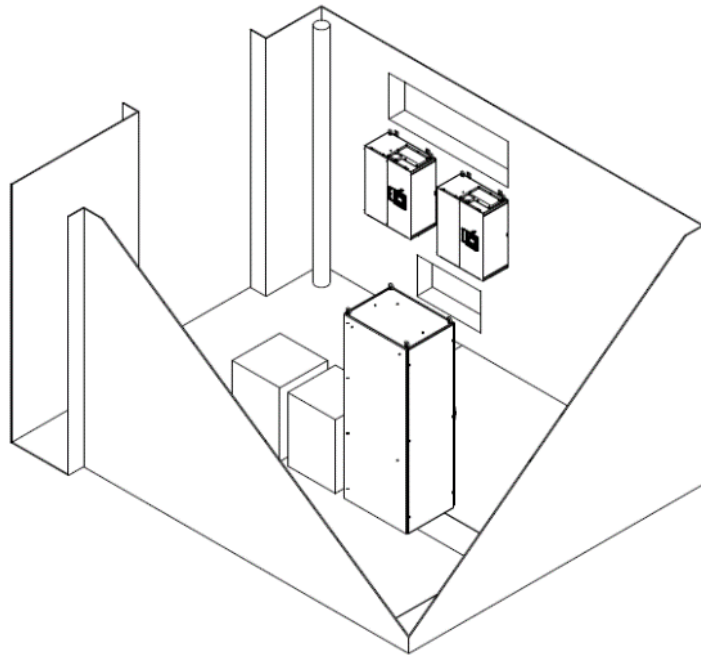

Battery energy storage systems

Product portfolio

Large systems

- Inverters
- Batteries
- Higher level controller (EMS)
- Documentation
- Optional services:
 - FAT
 - SAT
 - Commissioning assistance
- Large systems are suitable mainly for outdoor (in container) installation
- cooling control and fire fighting system is included
- Range: 500s kW to 2500s kW

Battery energy storage systems

Product portfolio

Large systems – Typical layout inside inverter container

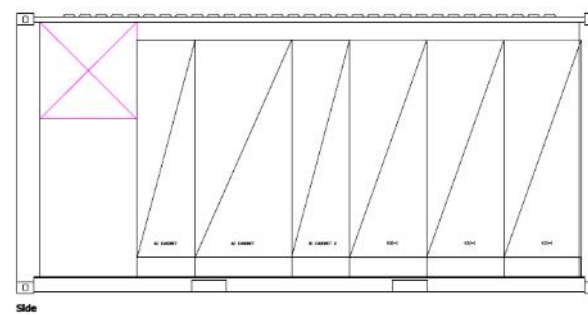
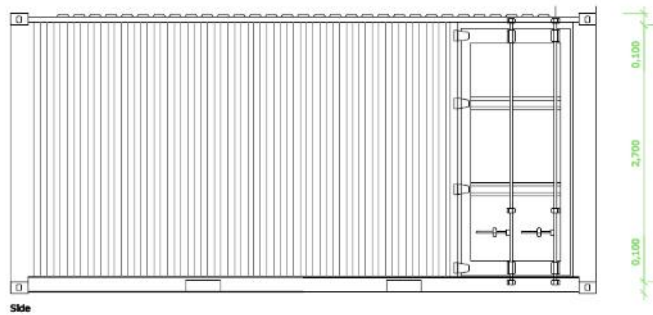

LEGEND	
	COMBINED SMOKE HEAT DETECTOR CONVENTIONAL
	OPTICAL SMOKE DETECTOR CONVENTIONAL
	FIRE ALARM PUSH BUTTON WITH BREAK GLASS SURFACE MOUNTED ENCLOSURE
	CO2 PORTABLE FIRE EXTINGUISHER - 8KG
	JG_S3 300 BAR 80L PRESSURIZED CYLINDER
	HVAC COOLING CIRCUIT PIPE NETWORK SEEING ACCORDING TO MANUFACTURER'S SPECIFICATION
	SURFACE MOUNTED INSIDE 100x60mm TRAY
	CONDENSATION EVACUATION

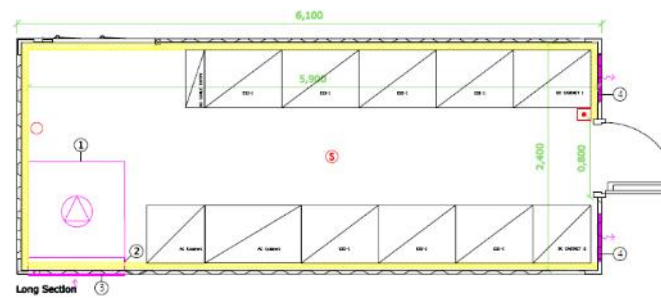

Battery energy storage systems

Product portfolio

Large systems – Typical layout inside battery container

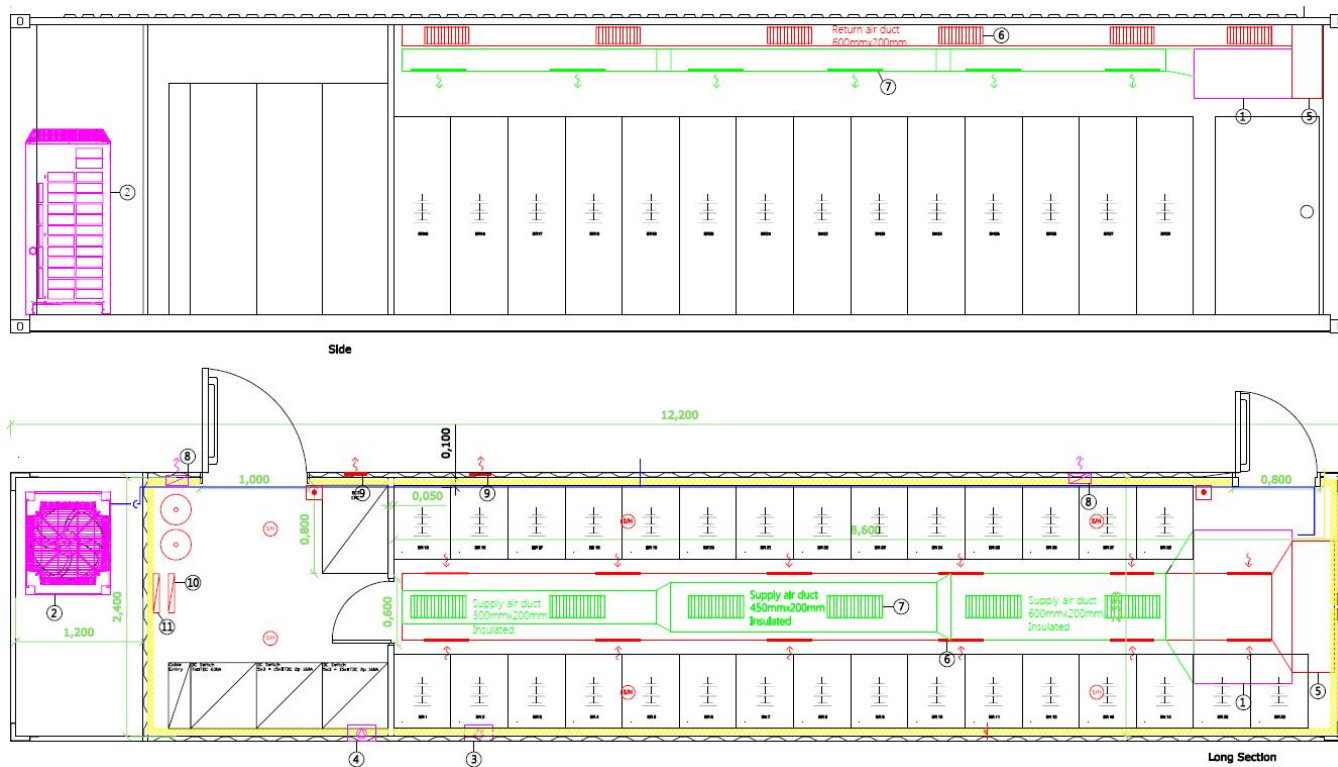

Battery energy storage systems

References

Falbygdens Energi – Falköping - Sweden

ESI-I range three phase, three wire

Year of commissioning - 2011

Goal of project:

- Study of integration of renewable: wind turbine
- Study of the ESI in a real application grid

Battery: Li-ion from LG

Power and energy rating:

- 75kW
- 135kWh

Features:

- Harmonic mitigation
- Power factor correction
- Load shifting
- Peak shaving



ESI-I and batteries

Battery energy storage systems

References

Oak Ridge - USA

ESI-S 100A single phase

Year of commissioning - 2012

Goal of project:

- Study of integration of renewable: solar panel
- Study of algorithms which optimize the network management

Battery: Li-ion from GM (Volt car battery)

Power and energy rating:

- 25kW
- 25kWh

Features:

- Islanding
- Harmonic mitigation
- Power factor correction
- Remote communication: Modbus RTU



Battery energy storage systems

References

Nordhavn - Denmark

- Complete battery system for storage of renewable energy from a residential harbour district
- Connected to Nordhavn's electricity grid to supply 60 households with electricity for up to 24 hours
- Urban laboratory for energy solutions
- Solution: ABB's ESI Inverters
 - Output: 630 kW
 - Energy: 460 kWh
 - Technology: Li-ion
 - Commissioning: January 2017



Battery energy storage systems

630kW, 460 kWh system

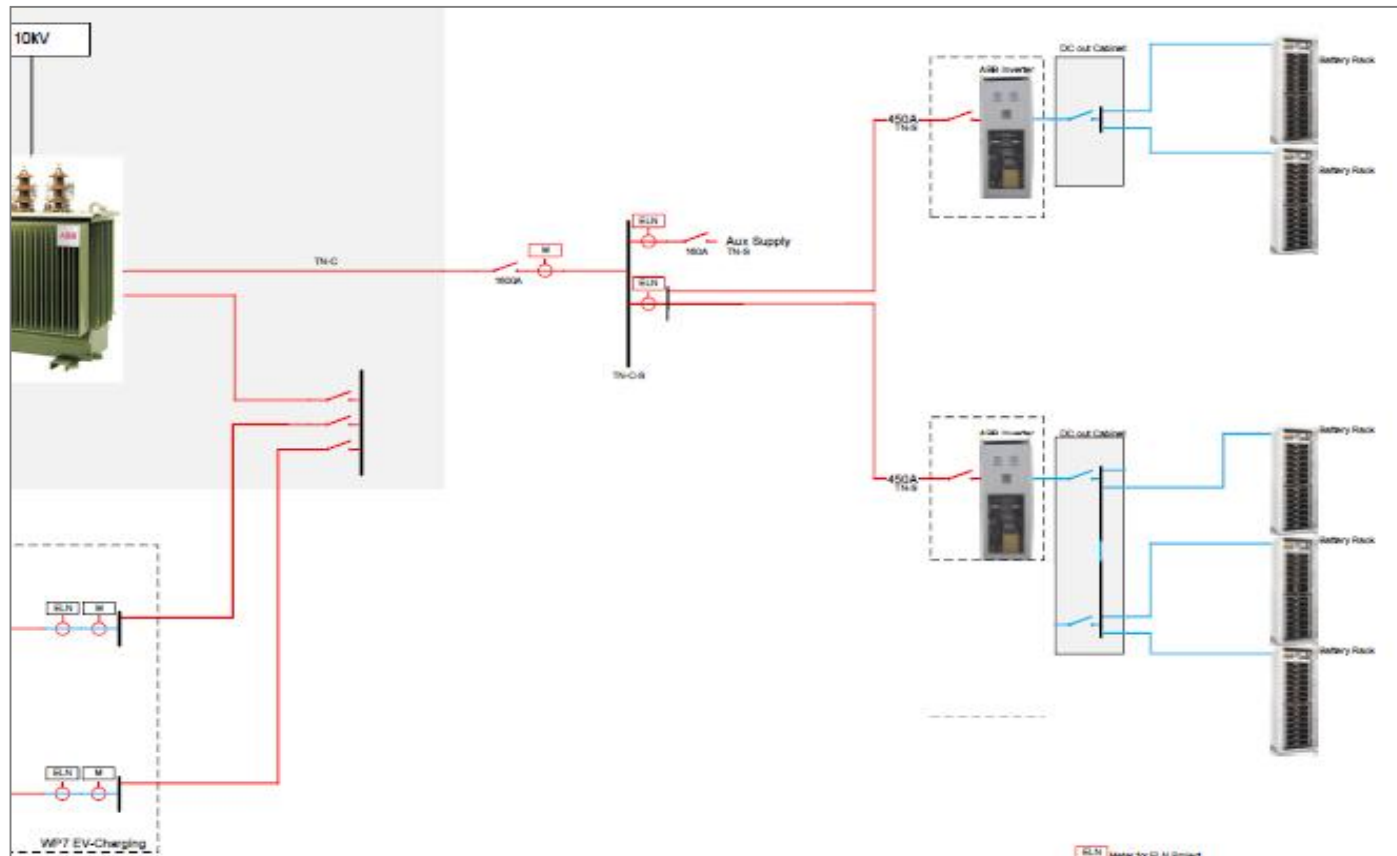

Battery energy storage systems

630kW, 460 kWh system

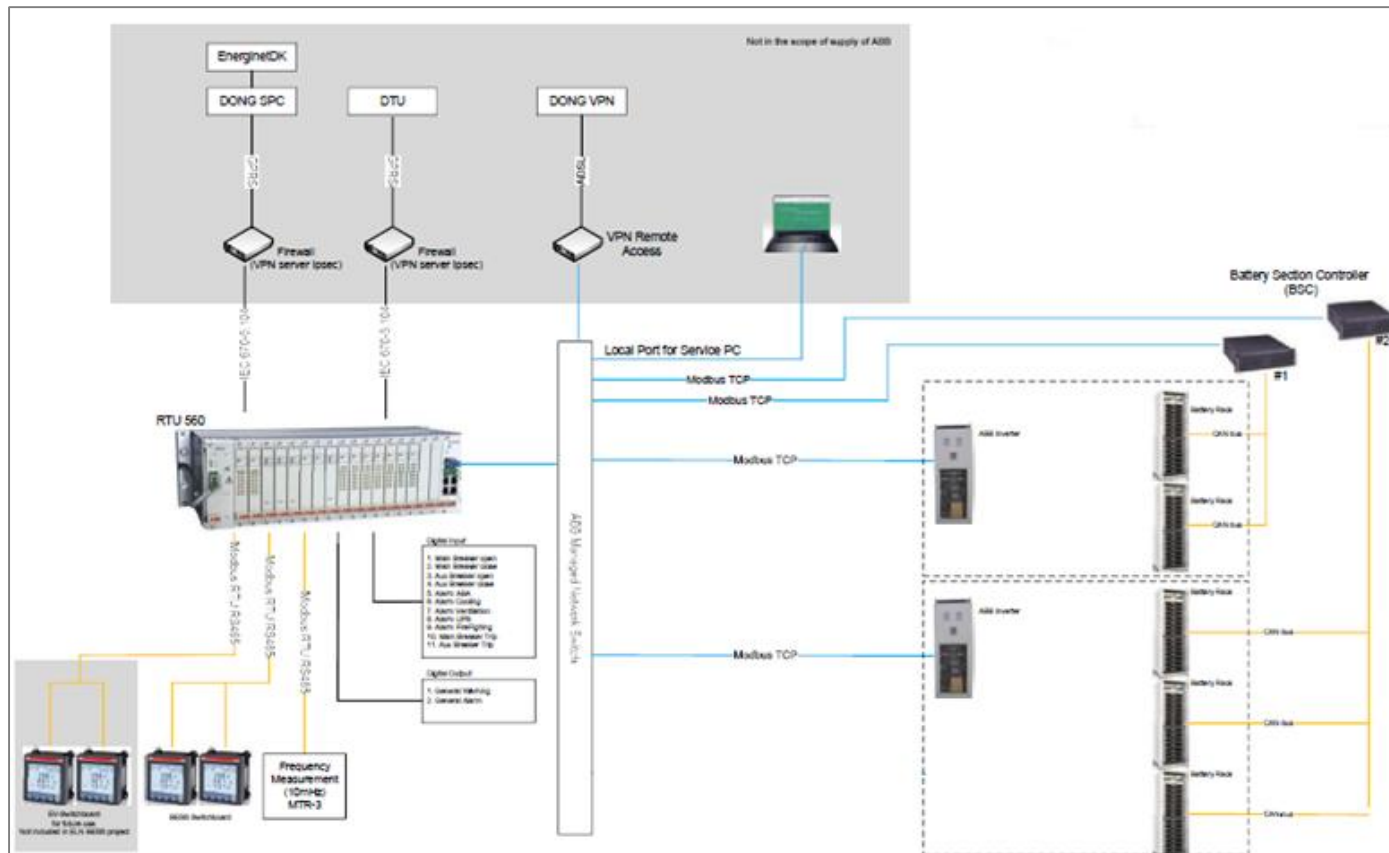

Battery energy storage systems and inverters

ABB as a partner

ABB supports customers in finding the right solution

- We have a global offering supported by local expertise and service
- We provide consultancy to determine the optimum technical solution to meet the customer's needs
- We design the solution to maximize the value generation and return on investment for the customer

ABB has an offering to meet all customer needs

- We offer turnkey battery energy storage facilities
- We offer integrated converter and battery systems
- We offer converter systems without batteries

ABB is independent of battery technology

- We manufacture battery energy storage systems but not batteries
- Our independence lets us select the optimum battery technologies for our customers
- We take full responsibility for our selection

—

ABB